

GPR378

Body-Solid®

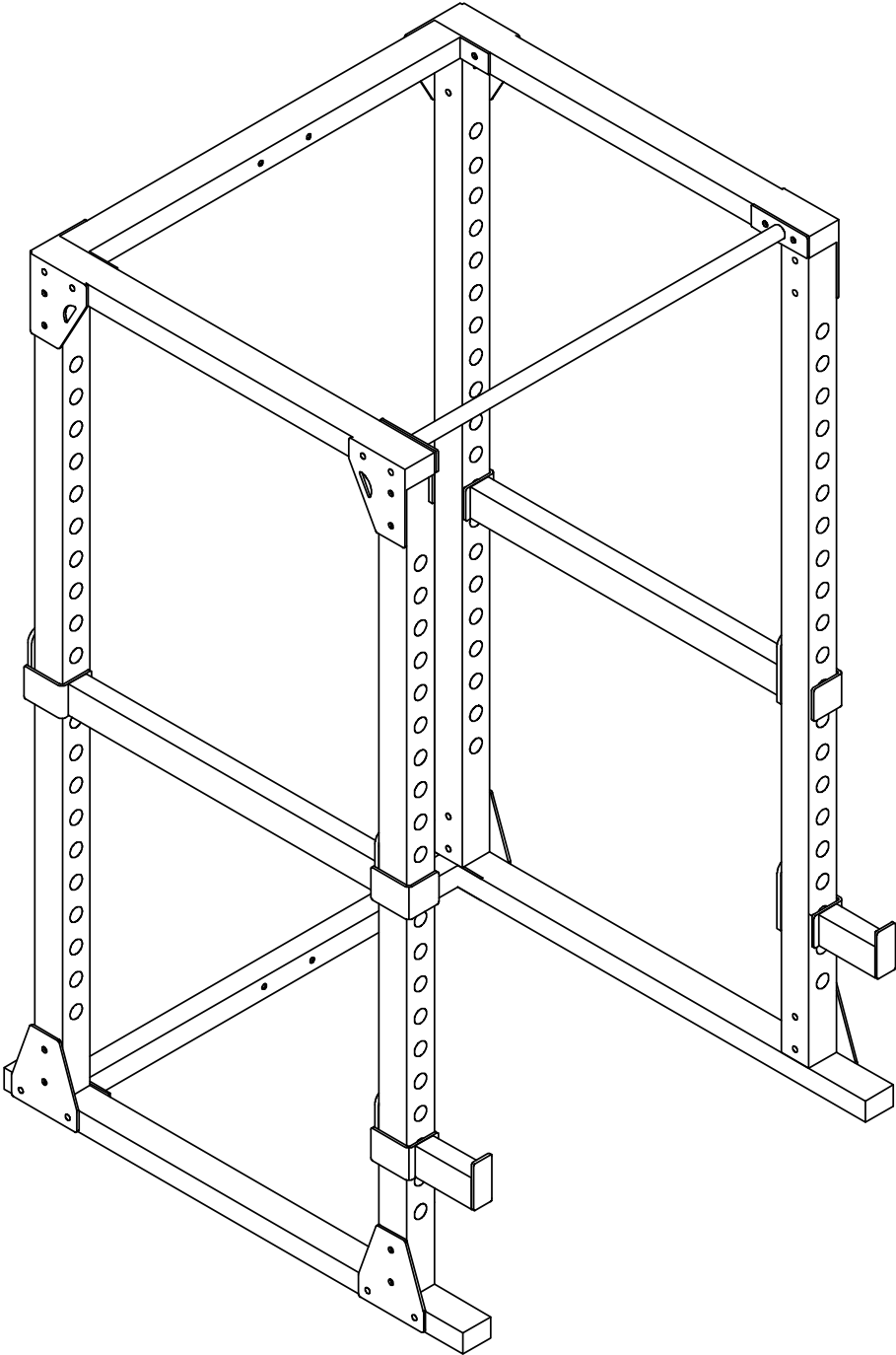

Assembly & Instructions
OWNER'S MANUAL

STEP

1

Be careful to assemble all components in the sequence they are presented.

NOTE:

Finger tighten all hardware in this step. Do Not wrench tighten until end of Step 5.

- A. Attach the Right Side Bottom Frame (6R) to Rear Bottom Frame (7) by using:
Two 13 (1/2" x 4" hex head bolt)
Four 15 (1/2" washer)
Two 14 (1/2" nylon lock nut)
- B. Attach the Left Side Bottom Frame (6L) to Rear Bottom Frame (7) by using:
Two 13 (1/2" x 4" hex head bolt)
Four 15 (1/2" washer)
Two 14 (1/2" nylon lock nut)

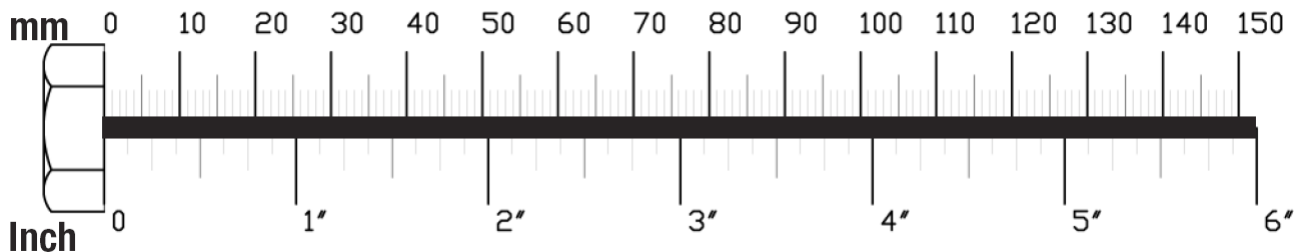

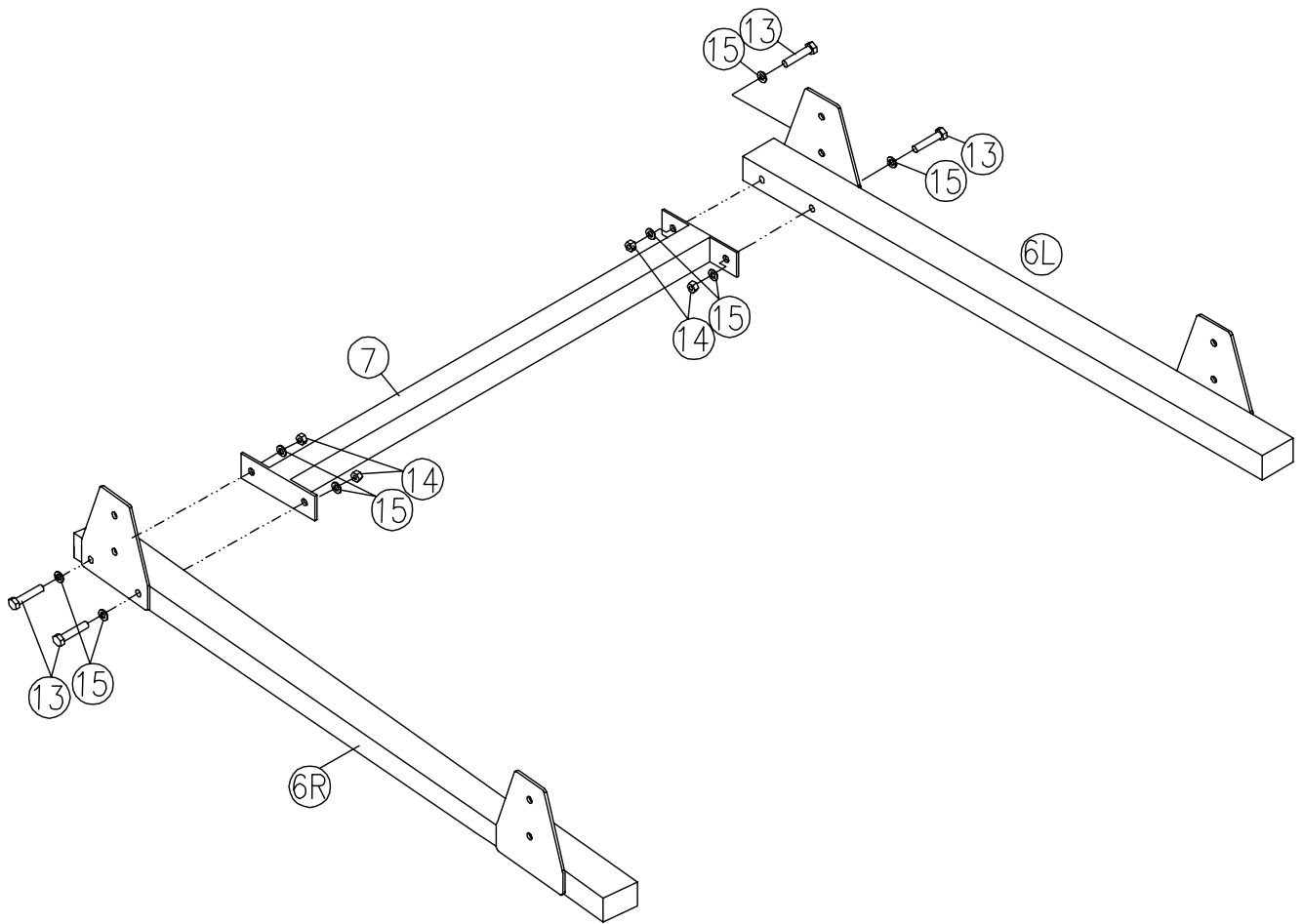

STEP

2

Be careful to assemble all components in the sequence they are presented.

NOTE:

Finger tighten all hardware in this step. Do Not wrench tighten until end of Step 5.

- A. Connect Back Upright (1) and Front Upright (2) to Right Side Bottom Frame (6R) by using:
Four 12 (1/2" x 4" hex head bolt)
Eight 15 (1/2" washer)
Four 14 (1/2" nylon lock nut)

- B. Connect Back Upright (1) and Front Upright (2) to Left Side Bottom Frame (6L) by using:
Four 12 (1/2" x 4" hex head bolt)
Eight 15 (1/2" washer)
Four 14 (1/2" nylon lock nut)

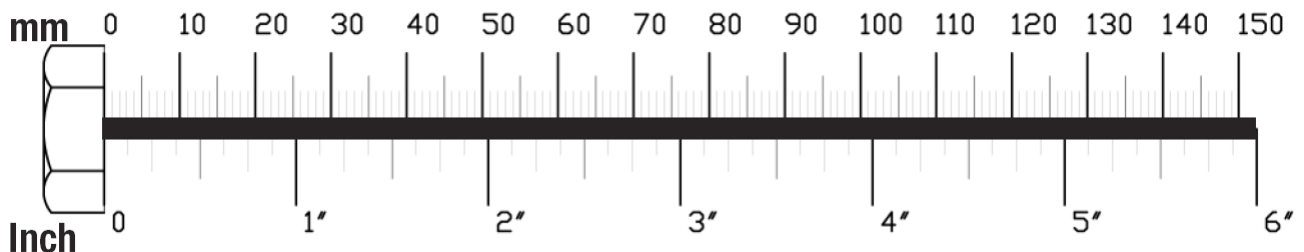

STEP
2

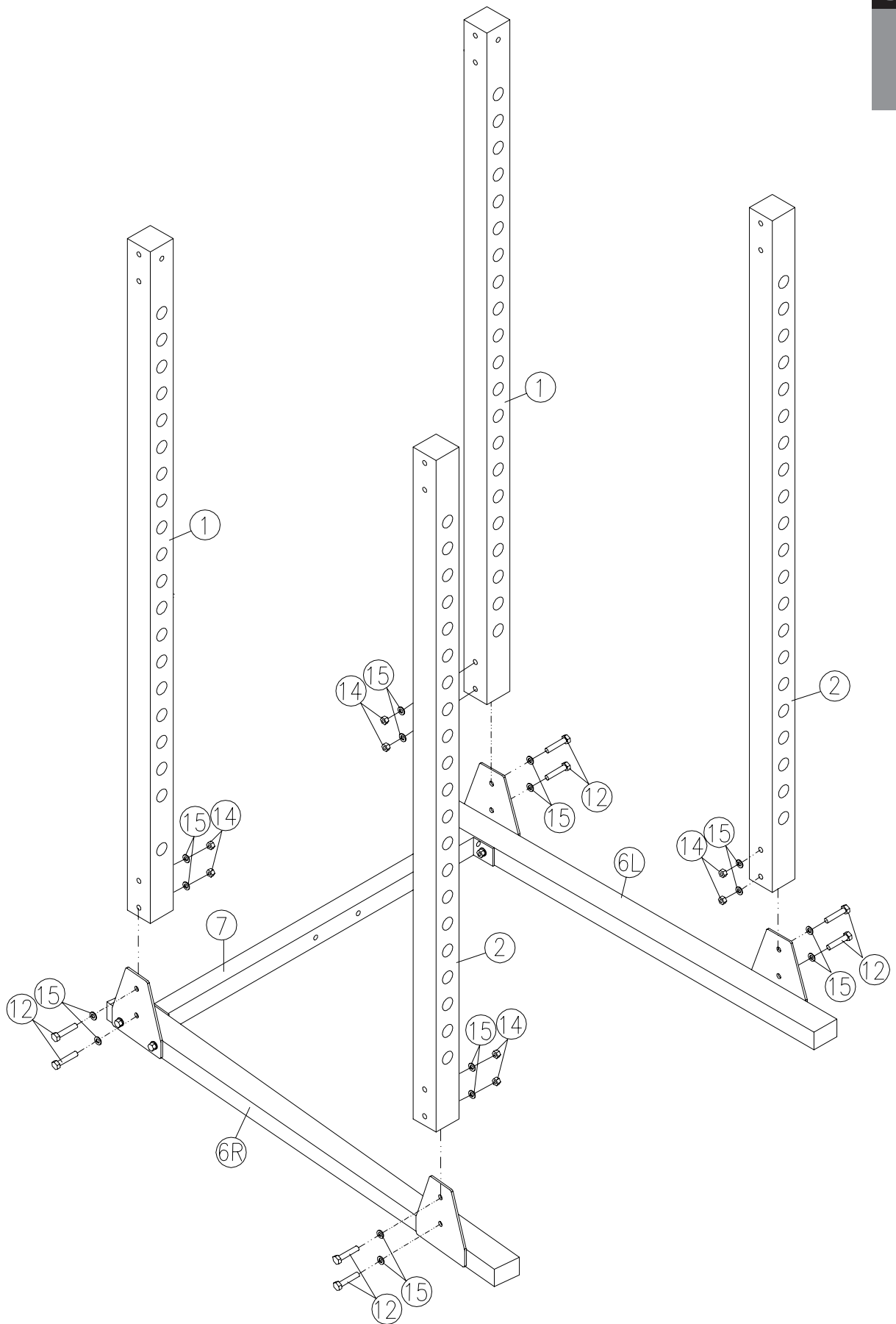

STEP**3**

Be careful to assemble all components in the sequence they are presented.

NOTE:

Finger tighten all hardware in this step. Do Not wrench tighten until end of Step 5.

- A. Attach Left Side Top Frame (3L) to Back Upright (1) and Front Upright (2) by using:
Four 12 (1/2" x 4" hex head bolt)
Eight 15 (1/2" washer)
Four 14 (1/2" nylon lock nut)
- B. Attach Right Side Top Frame (3R) to Back Upright (1) and Front Upright (2) by using:
Four 12 (1/2" x 4" hex head bolt)
Eight 15 (1/2" washer)
Four 14 (1/2" nylon lock nut)

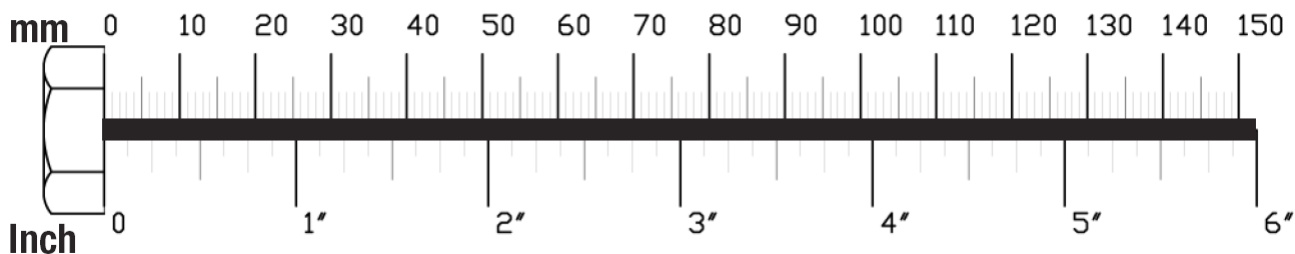

STEP
3

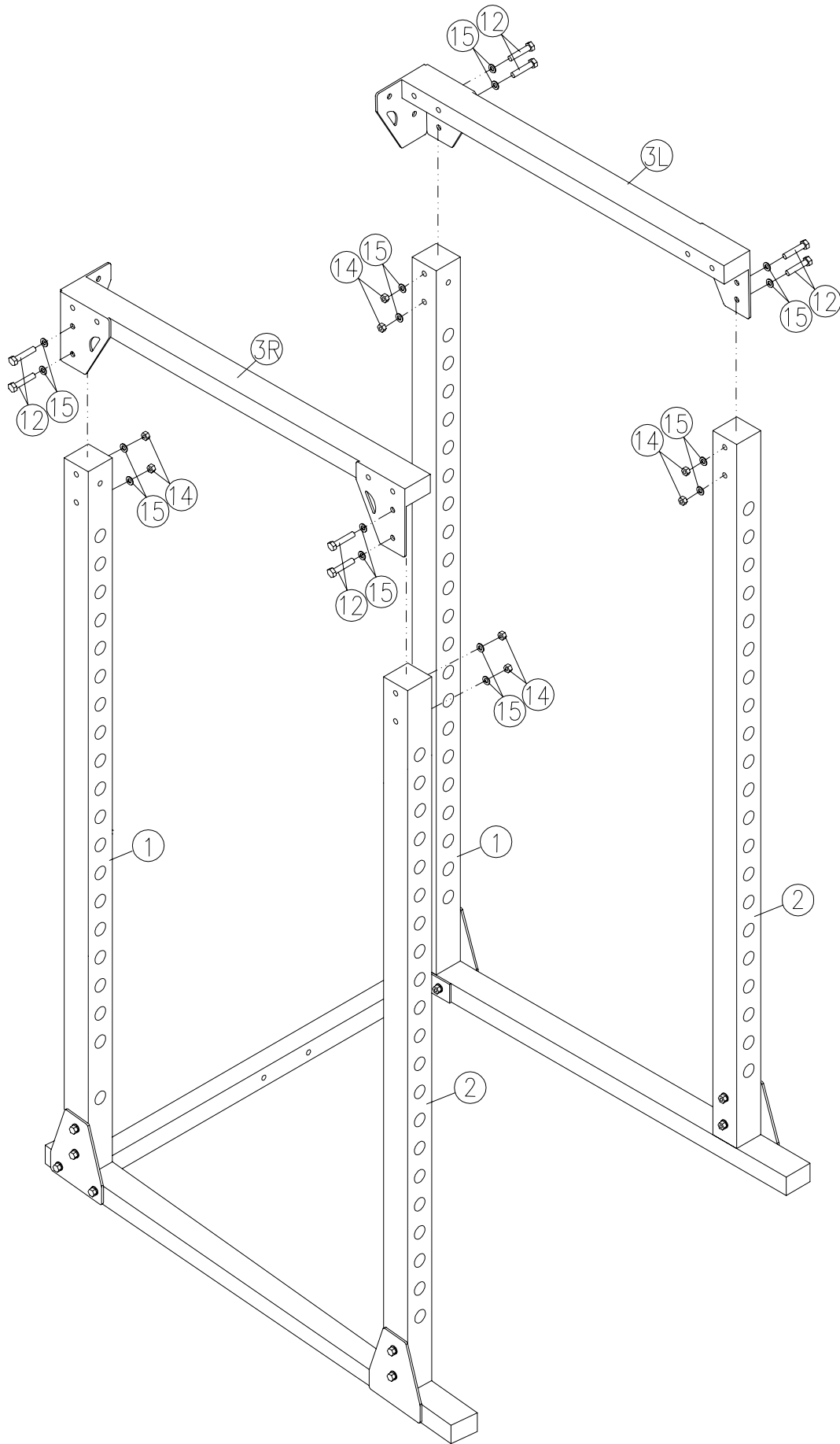

STEP**4**

Be careful to assemble all components in the sequence they are presented.

NOTE:

Finger tighten all hardware in this step. Do Not wrench tighten until end of Step 5.

- A. Connect Rear Top Frame (5) to Left Side Top Frame (3L) and Right Side Top Frame (3R) by using:
Six 12 (1/2" x 4" hex head bolt)
Ten 15 (1/2" washer)
Four 14 (1/2" nylon lock nut)
- B. Connect Chin Up Bar (4) to Left Side Top Frame (3L) and Right Side Top Frame (3R) by using:
Four 13 (1/2" x 4 1/8" hex head bolt)
Eight 15 (1/2" washer)
Four 14 (1/2" nylon lock nut)

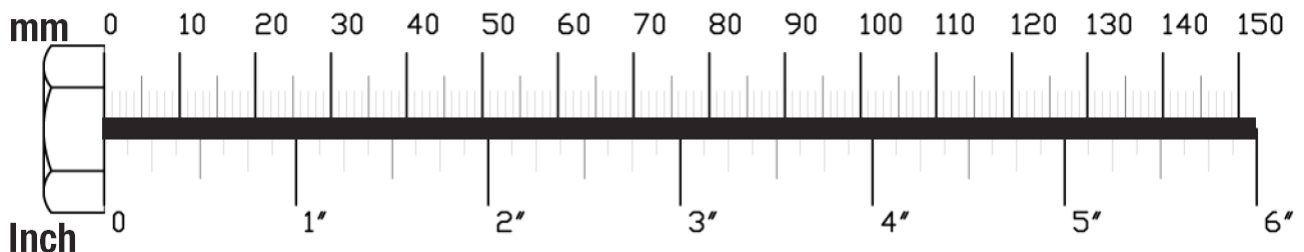

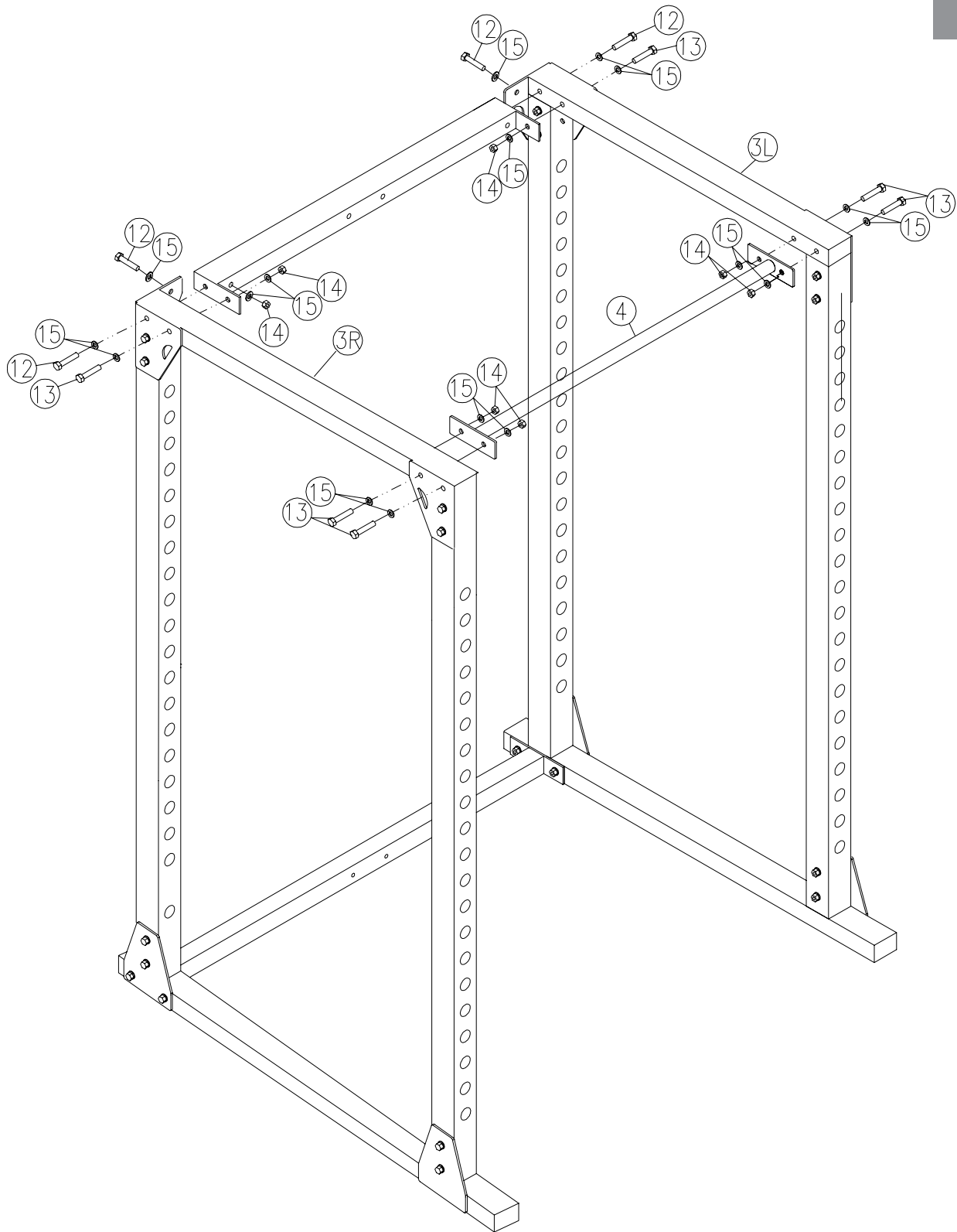

STEP

5

Be careful to assemble all components in the sequence they are presented.

NOTE:

Finger tighten all hardware in this step. Do Not wrench tighten until end of Step 5.

- A. Connect Right Safety Catch (8R), Left Safety Catch (8L), Right Lift Off (9R), Left Lift Off (9L) to the desired positions.
- B. Enjoy your workout!

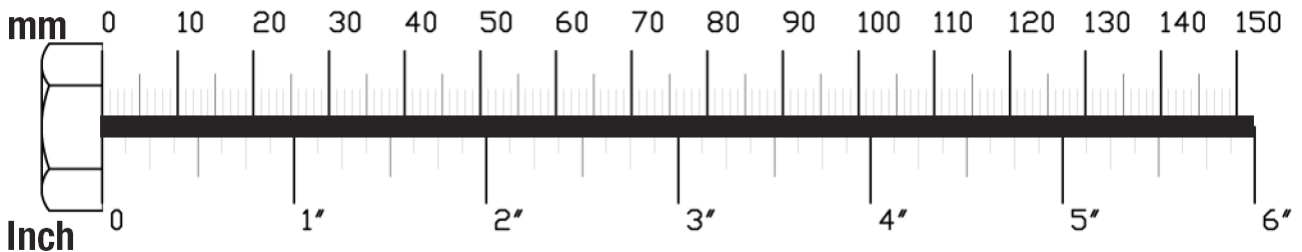

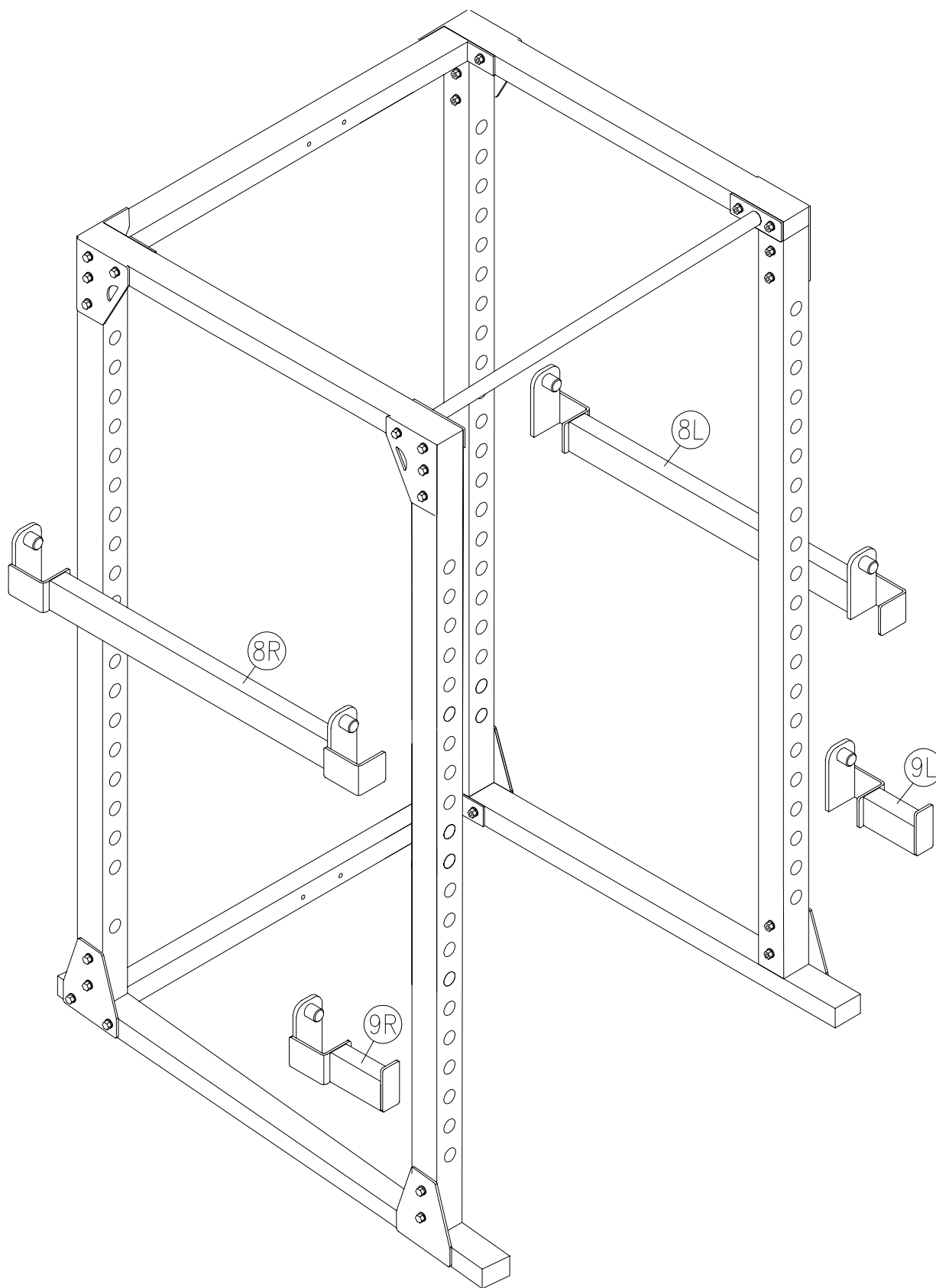

GLA 378 Hardware

PART#	QTY	DESCRIPTION
1	2	BACK UPRIGHT
2	2	FRONT UPRIGHT
3	2	SIDE TOP FRAME
4	1	CHIN UP BAR
5	1	REAR TOP FRAME
6	1	SIDE BOTTOM FRAME
7	1	REAR BOTTOM FRAME
8	2	SAFETY CATCH
9	2	LIFT OFF
10	12	CUSHION
11	4	END CAP 3"x2"
12	20	HEX HEAD BOLT 1/2"x4" PARTIAL THREAD
13	10	HEX HEAD BOLT 1/2"x4 1/8" PART.THR.
14	30	1/2" NYLON LOCK NUT
15	60	1/2" WASHER
16	2	END CAP 3"x2"

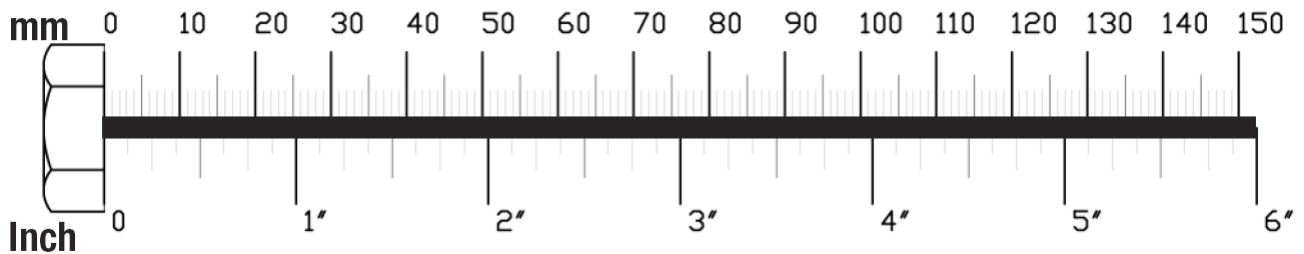

GLA378

Exploded View

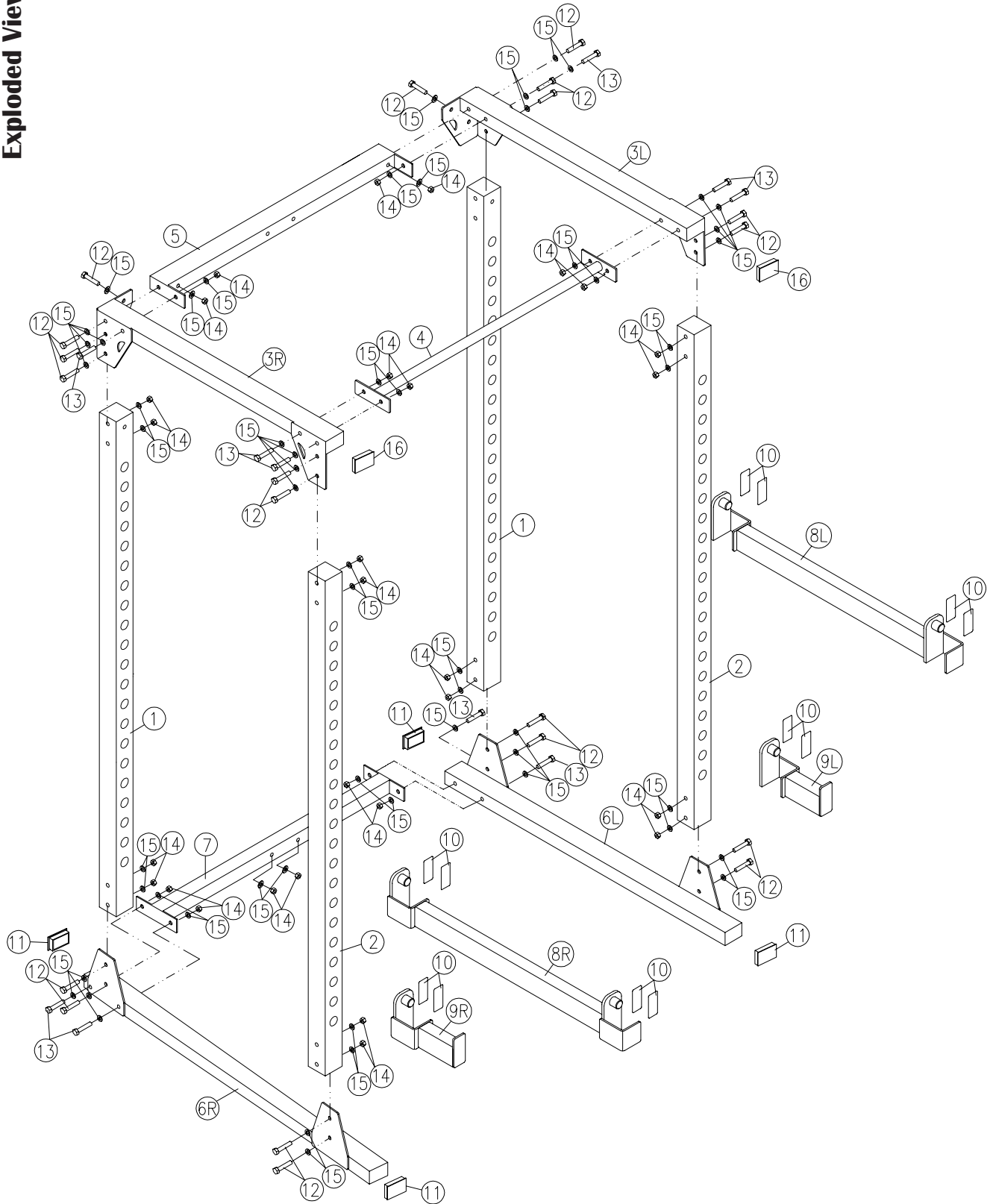

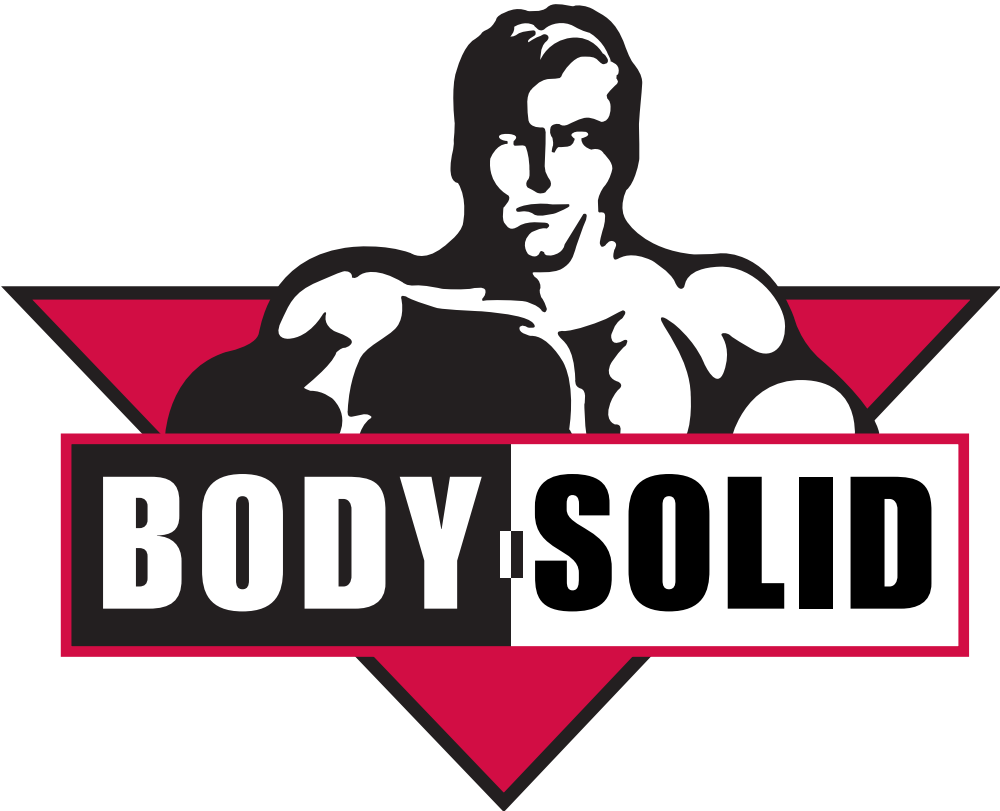

BODY-SOLID