

GKR9

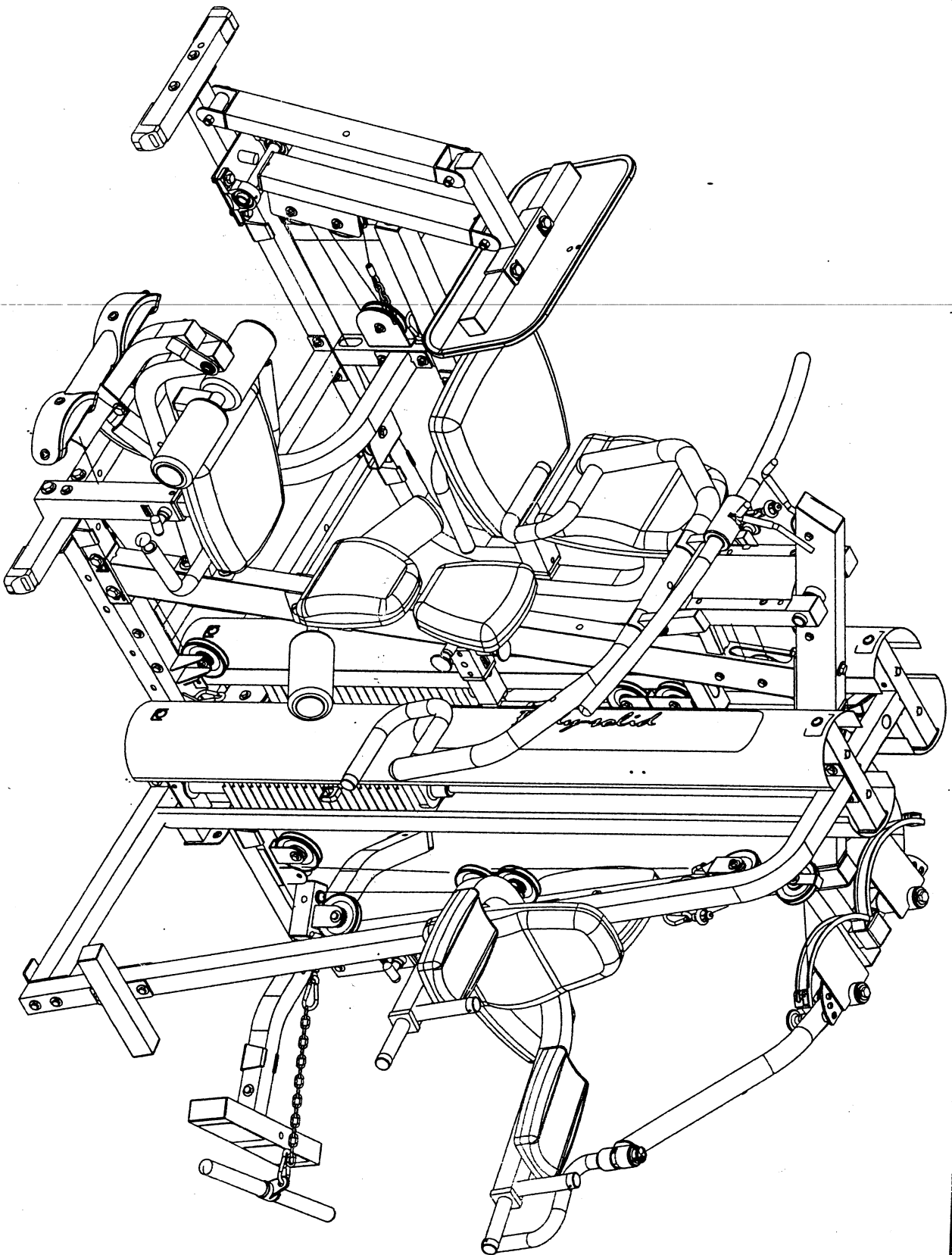

VE^{rs}ION 0904

HARDWARE ILLUSTRATION SHEET

Part No.	Description	Qty.
A1.	3/8"X3" HEX HEAD BOLT	[4PCS]
A2.	3/8"X2 3/4" HEX HEAD BOLT	[4PCS]
A3.	3/8"X2 1/2" HEX HEAD BOLT	[4PCS]
A4.	5/16"X2 3/4" HEX HEAD BOLT	[2PCS]
A5.	5/16"X1" HEX HEAD BOLT	[4PCS]
B1.	3/8" NYLON LOCK NUT	[2PCS]
C1.	3/8" (I.D.)WASHER	[8PCS]
C2.	5/16" (I.D.)WASHER	[18PCS]
C3.	5/16" SPRING WASHER	[6PCS]
D1.	2"X2"X1.8t END CAP (9211-005)	[2PCS]
D2.	95X140mm NO-SLIP TAPE (9310-035)	[2PCS]

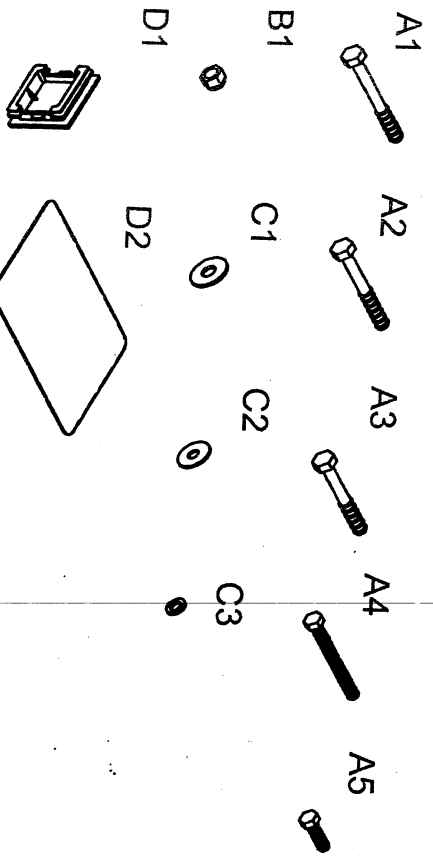

PARTS ILLUSTRATION SHEET

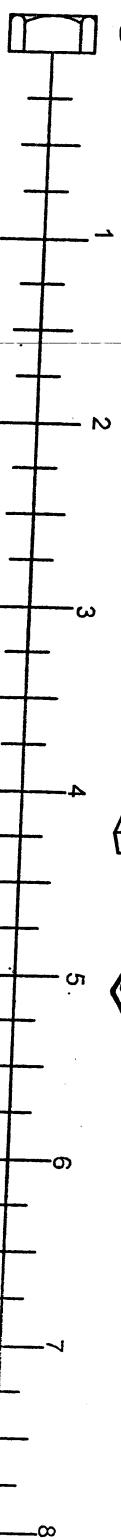
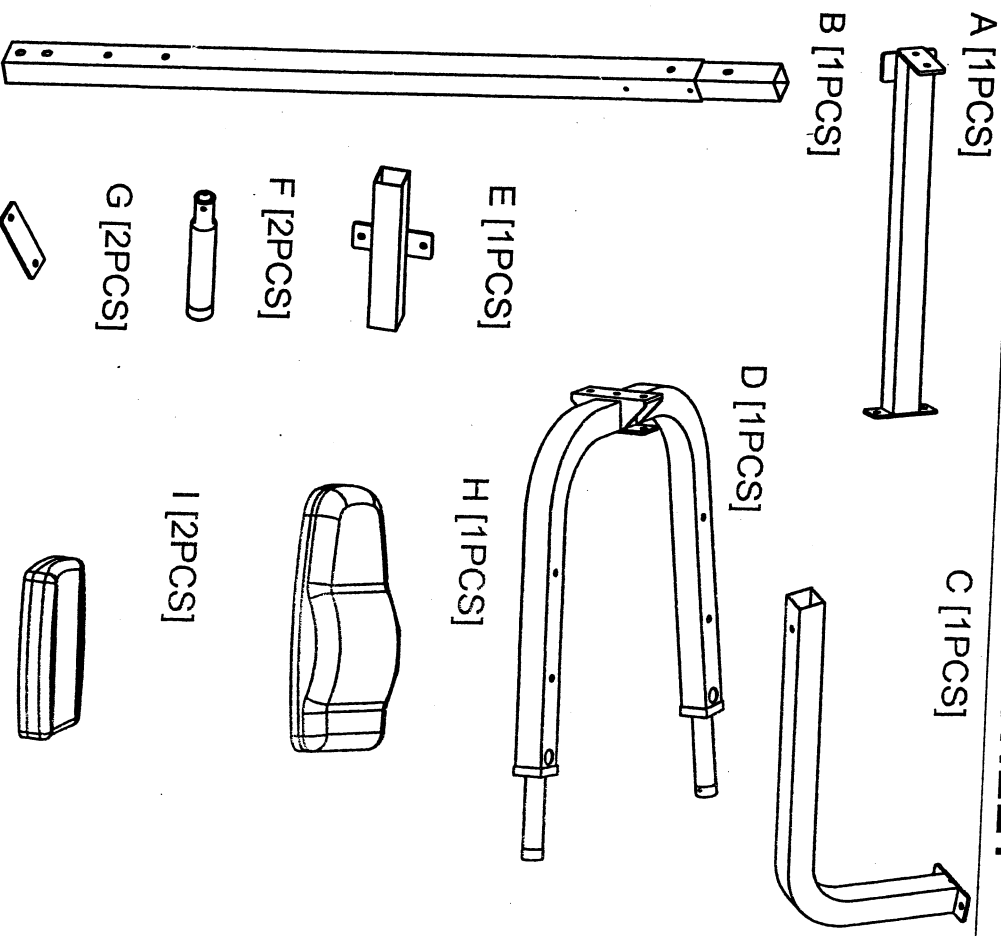

GKR9

