

# Body-Solid

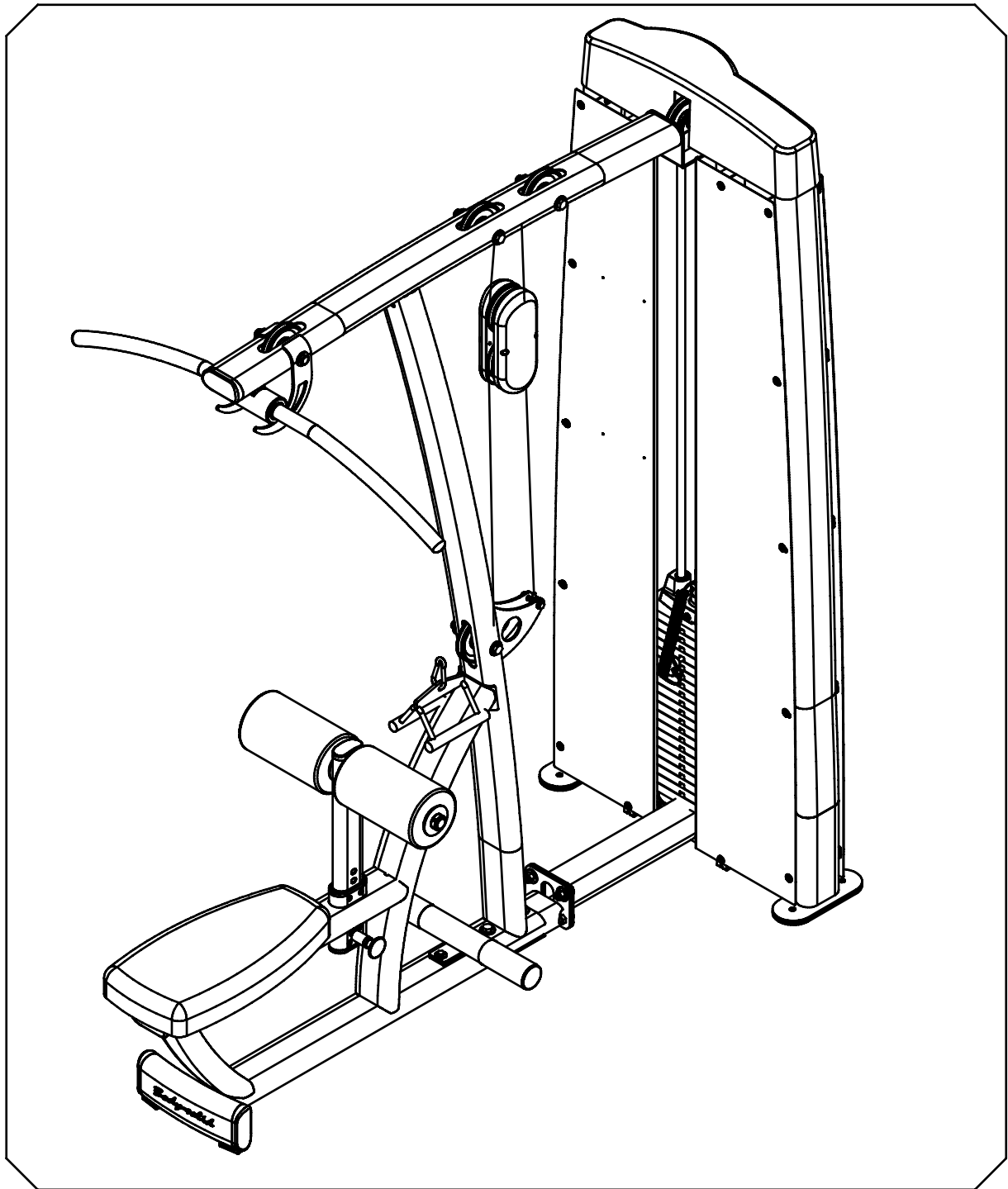

BODY-SOLID, Inc.  
1900 S. Des Plaines Ave.  
Forest Park, IL 60130 USA  
Phone: (708) 427-3555  
Fax: (708) 427-3556  
[www.bodysolid.com](http://www.bodysolid.com)

## DLAT OWNER'S MANUAL

# DLAT ASSEMBLY INSTRUCTIONS

## HARDWARE ILLUSTRATION

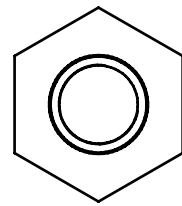
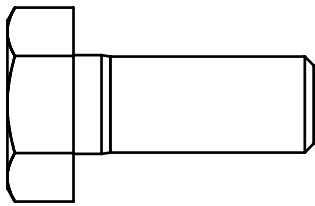

(A1)HEX BOLT 1/2"x1 1/4"L PARTIAL THREAD QTY.2

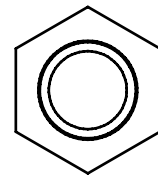
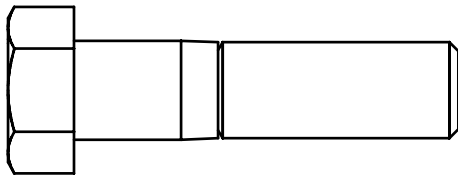

(A2)HEX BOLT 1/2"x2"L PARTIAL THREAD QTY.2

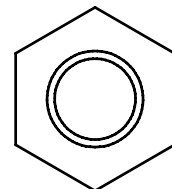
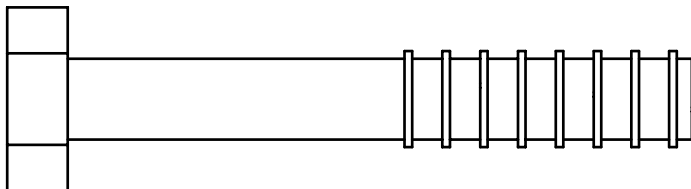

(A3)HEX BOLT 1/2"x3 1/4"L PARTIAL THREAD QTY.1

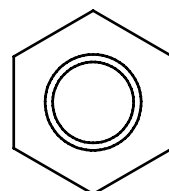
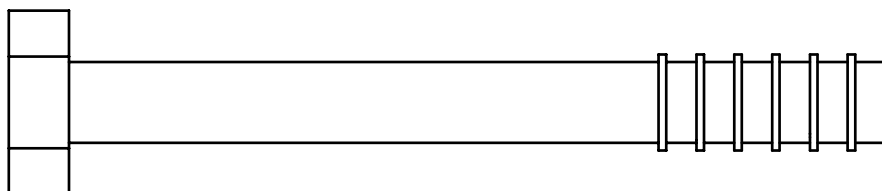

(A4)HEX BOLT 1/2"x4 1/4"L PARTIAL THREAD QTY.2

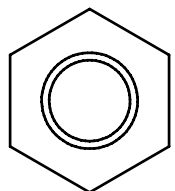
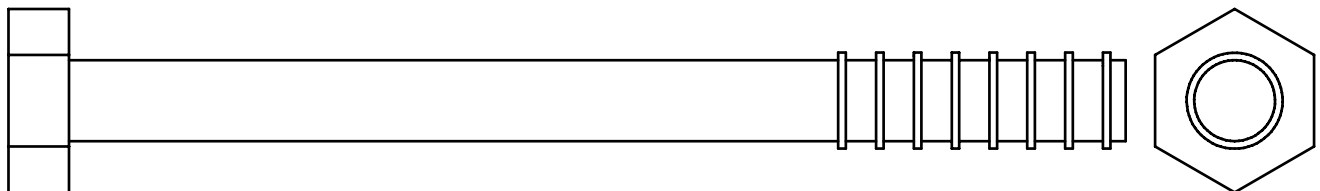

(A5)HEX BOLT 1/2"x5 1/2"L PARTIAL THREAD QTY.3

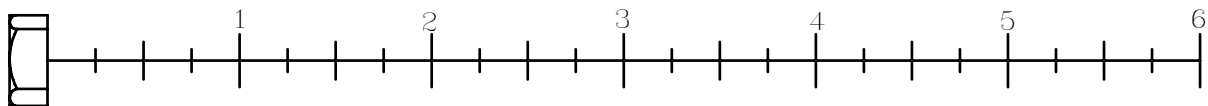

# DLAT ASSEMBLY INSTRUCTIONS

## HARDWARE ILLUSTRATION

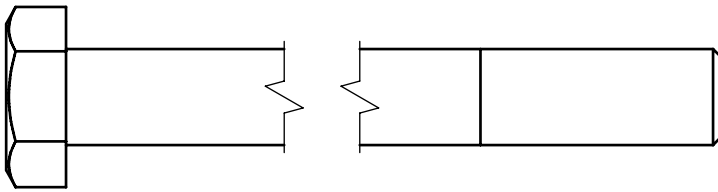

(A6)HEX BOLT 1/2"x5 3/4"L PARTIAL THREAD QTY.1

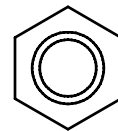
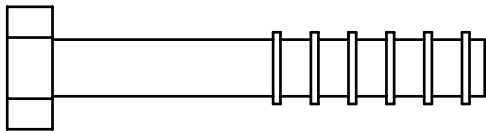

(A7)HEX BOLT 3/8"x2 1/4"L PARTIAL THREAD QTY.1

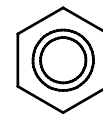
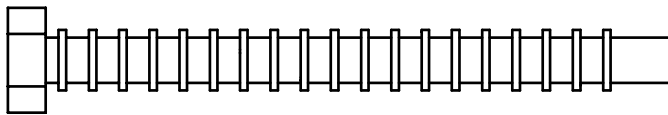

(A9)HEX BOLT 5/16"x3 1/4"L PARTIAL THREAD QTY.2

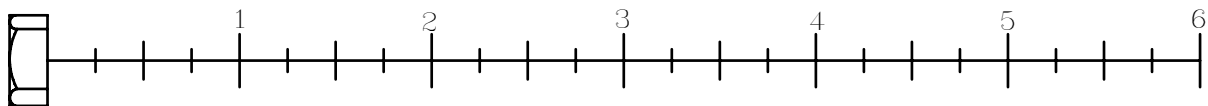

# DLAT ASSEMBLY INSTRUCTIONS

## HARDWARE ILLUSTRATION CONNECT DGYM

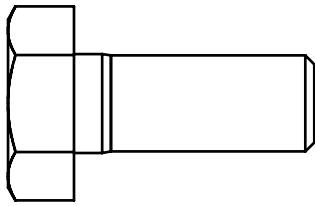

(A10)HEX BOLT 1/2"x1 1/4"L PARTIAL THREAD QTY.4

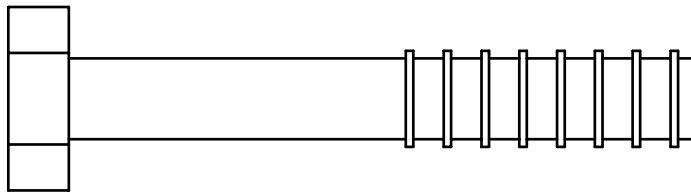
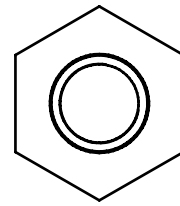

(A11)HEX BOLT 1/2"x3 1/4"L PARTIAL THREAD QTY.1

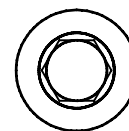
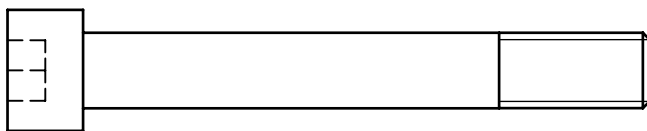
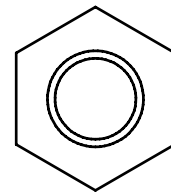

(A21)ROUND ALLEN HEAD M10X75L PARTIAL THREAD QTY.2

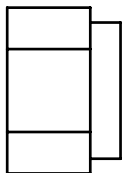

(B1)NYLON LOCK NUT 1/2" QTY.5

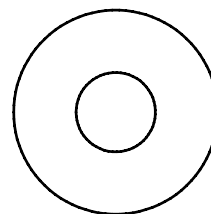
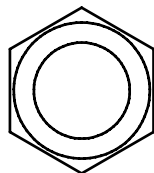

(C12)M10(I.D.)FLAT WASHER Ø27 QTY.2

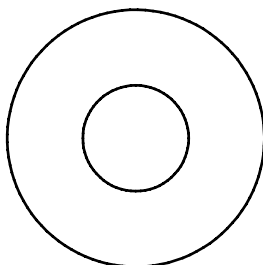

(C1)1/2"(I.D.)FLAT WASHER Ø34 QTY.10

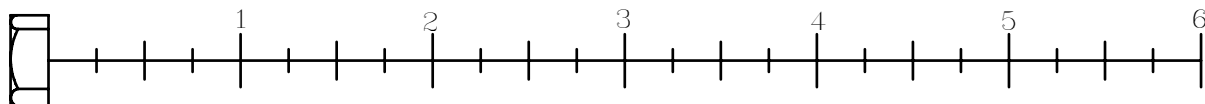

# DLAT ASSEMBLY INSTRUCTIONS

## FRAME HARDWARE ILLUSTRATION



(A12) ALLEN SCREW 5/16" X 3/8" L FULL THREAD QTY. 3

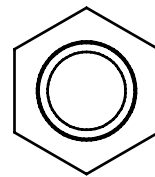
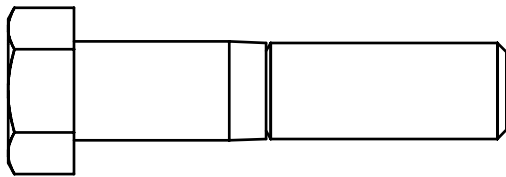

(A13) HEX BOLT 1/2" X 2 1/4" L PARTIAL THREAD QTY. 1

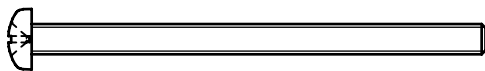

(A14) HEX BOLT M4 X 65 L" L PARTIAL THREAD QTY. 2

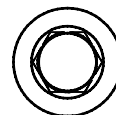
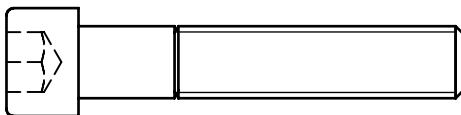

(A15) ROUND ALLEN HEAD 3/8" X 2" L PARTIAL THREAD QTY. 1

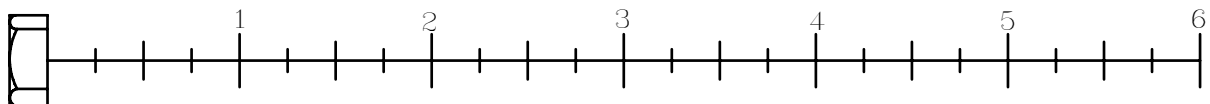

# DLAT ASSEMBLY INSTRUCTIONS

## FRAME HARDWARE ILLUSTRATION

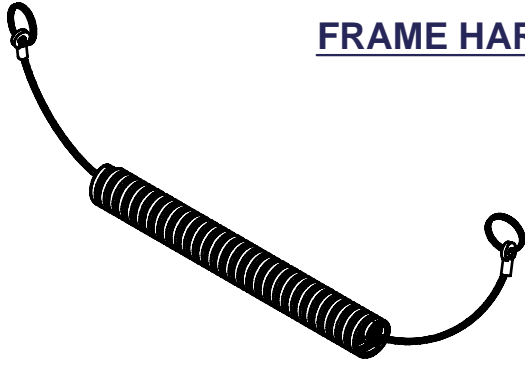

(A16)ELASTIC BOLT QTY.1

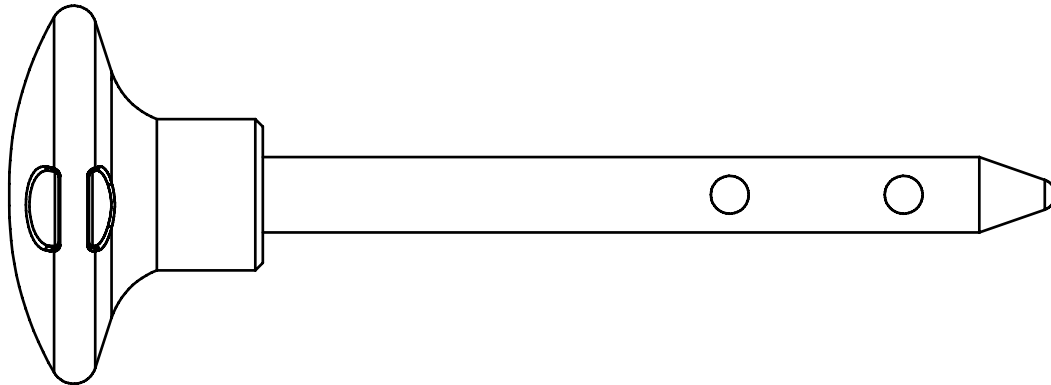

(A17)10LB PIN (8250-071) QTY.1

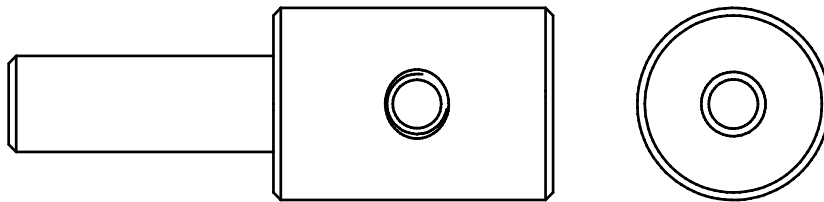

(A18)WEIGHT STACK CABLE (8260-009) QTY.1



(A19)ROUND ALLEN HEAD M6X20L PARTIAL THREAD QTY.24



(A20)ROUND ALLEN HEAD 5/32"X1/4"L PARTIAL THREAD QTY.4

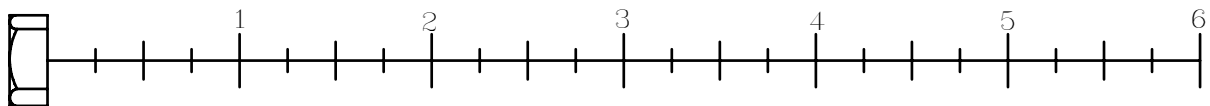

# DLAT ASSEMBLY INSTRUCTIONS

## HARDWARE ILLUSTRATION

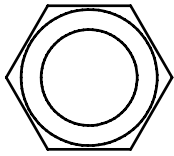

(B2) NYLON LOCK NUT 1/2" QTY.10

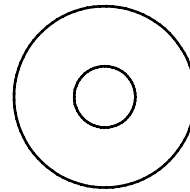
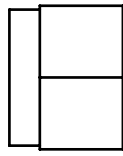

(C5) 5/16" (I.D.) FLAT WASHER Ø24 QTY.2

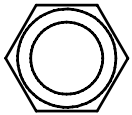

(B3) NYLON LOCK NUT 3/8" QTY.1

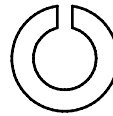
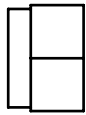

(C6) 5/16" SPRING WASHER QTY.2

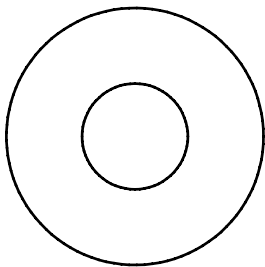

(C3) 1/2" (I.D.) FLAT WASHER Ø34 QTY.21

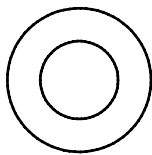
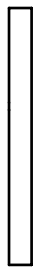

(C4) 3/8" (I.D.) FLAT WASHER Ø19 QTY.2

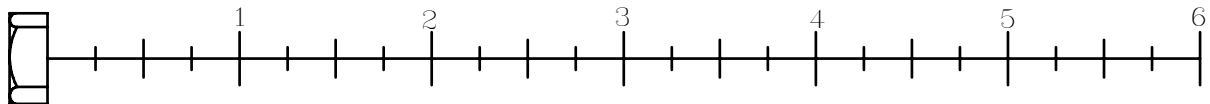

# DLAT ASSEMBLY INSTRUCTIONS

## FRAME HARDWARE ILLUSTRATION

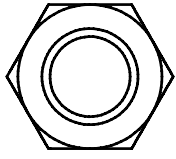

(B4) NYLON LOCK NUT 1/2" X 13 UNC X 8 T QTY. 1

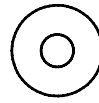

(C10) M4 (I.D.) FLAT WASHER Ø12 QTY. 2

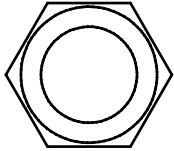

(B5) NYLON LOCK NUT 1/2" QTY. 1

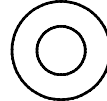
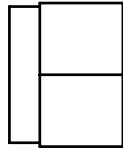

(C11) M6 (I.D.) FLAT WASHER Ø13 QTY. 24

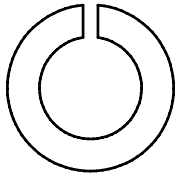

(C7) 1/2" SPRING WASHER QTY. 1

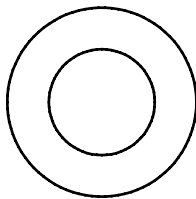
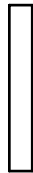

(C8) 1/2" (I.D.) FLAT WASHER Ø25 QTY. 2

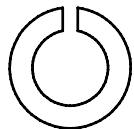
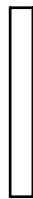

(C9) 3/8" SPRING WASHER QTY. 1

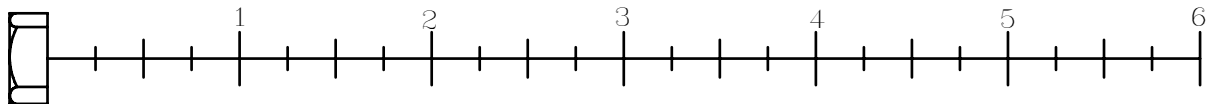



# DLAT ASSEMBLY INSTRUCTIONS

## HARDWARE ILLUSTRATION

D1.Ø3/4"X16L STEEL BUSHING (8110-066)	[2PCS]
D2.Ø3/4"X45L STEEL BUSHING (8110-067)	[8PCS]
D3.Ø1" SHAFT COLLAT(8130-024)	[2PCS]
D4.Ø8 SPRING SNAP LINK(8810-001)	[2PCS]
D5.Ø1" END CAP(9211-016)	[2PCS]
D6.Ø60 END CAP(9211-065)	[2PCS]
D7.50X100(40X80)NYLON BUSHING(9211-107)	[2PCS]
D8.58X116X2.5T FOOT CAP(9211-108)	[2PCS]
D9.COVER(9211-110)	[2PCS]
D10.58X116 END CAP(9211-112)	[2PCS]
D11.40X80 END CAP(9211-113)	[2PCS]
D12. 3" Nylon Washer (9214-008)	[4PCS]
D13. Ø1"x2.5t Round End Cap(9260-021)	[2PCS]
D14.Ø3/4" SHAFT COLLAR(9211-046)	[2PCS]
D15.Ø2 1/2"X19.2X19.4T RUBBER DOUNT(9310-010)	[2PCS]
D16.95X140L RUBBER PAD(9310-035)	[3PCS]
D17.95X250 RUBBER PAD(9310-060)	[2PCS]

D1



D2

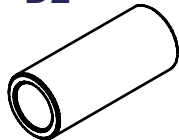

D3



D4



D5

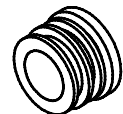

D6

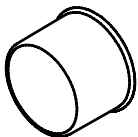

D7

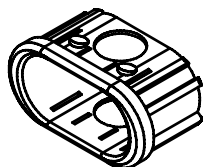

D8

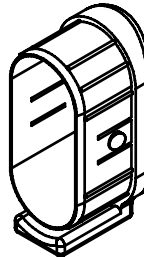

D9

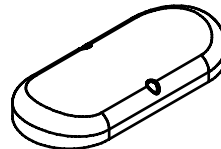

D10

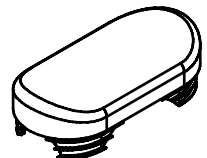

D11

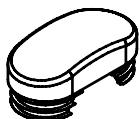

D12



D13

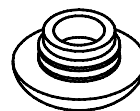

D14



D15

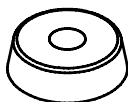

D16

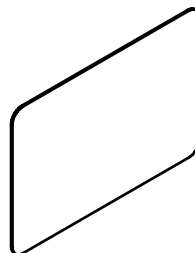

D17

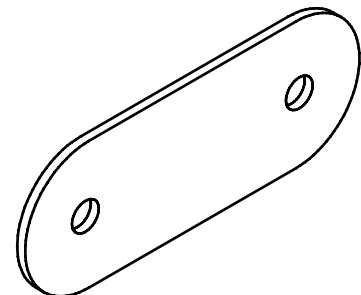

# DLAT ASSEMBLY INSTRUCTIONS

## HARDWARE ILLUSTRATION

D18.Ø117 PULLEY(9213-010B)-----	[8PCS]
D19.TOP PLATE(8400-006)-----	[1PCS]
D20.WEIGHT SELECTOR BAR(8210-042)-----	[1PCS]
D21.1975mm STEEL CABLE(FDLATA)-----	[1PCS]
D22.3270mm STEEL CABLE(FDLATB)-----	[1PCS]
D23.DLAT For DGYM Steel Cable(FDLATC)-----	[1PCS]

D18

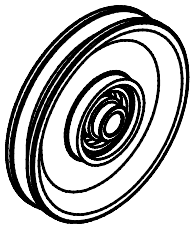

D19

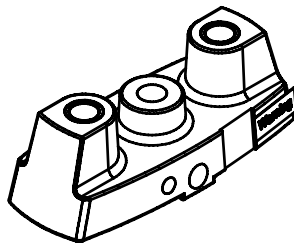

D20

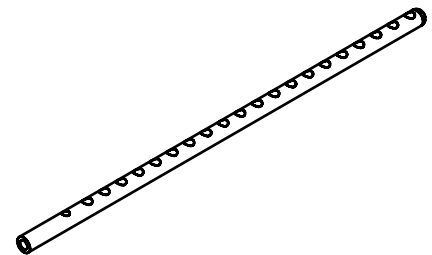

D21

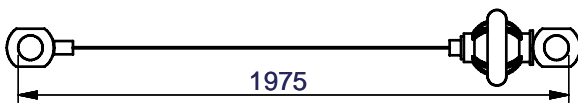

D22

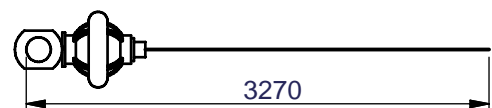

# DLAT ASSEMBLY INSTRUCTIONS

## PARTS ILLUSTRATION SHEET

A[1PCS]

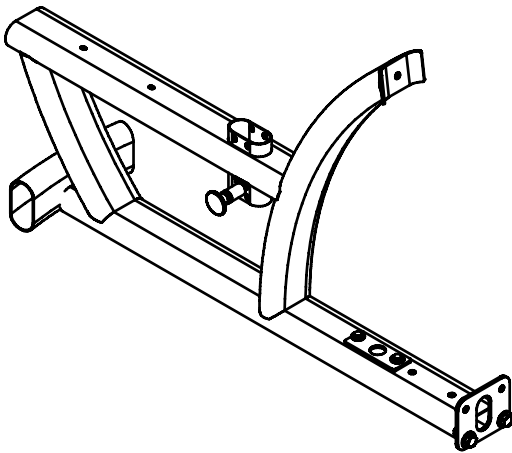

B[1PCS]

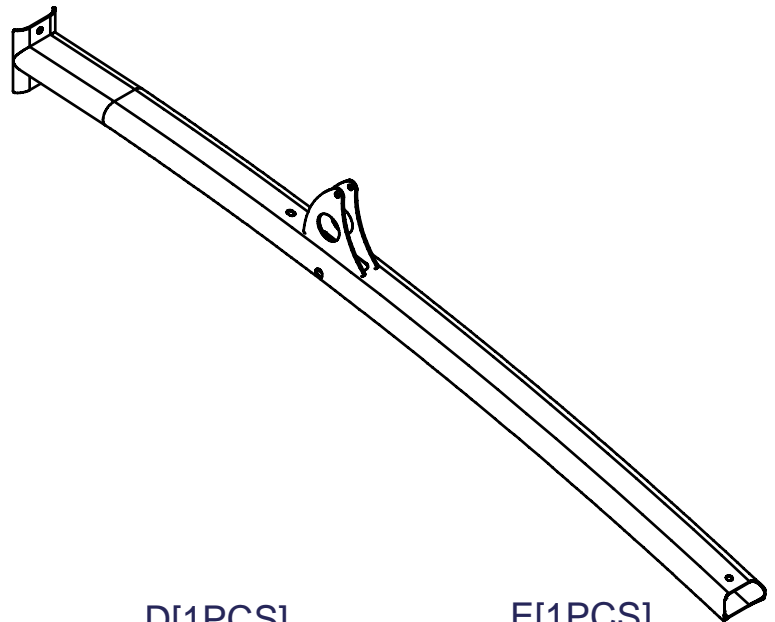

C[1PCS]

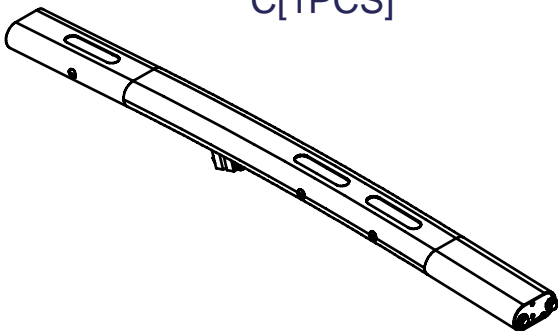

D[1PCS]

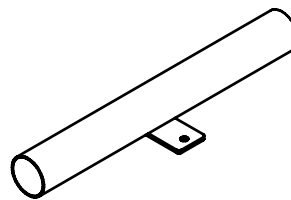

E[1PCS]

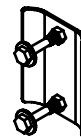

F[1PCS]

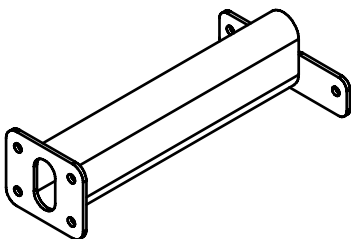

G[1PCS]  
CONNECT DGM

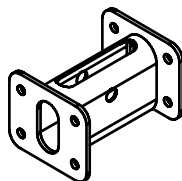

H[2PCS]

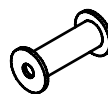

I[1PCS]

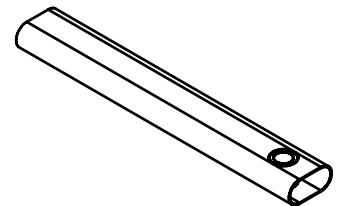

J[1PCS]  
Ø1"X600L

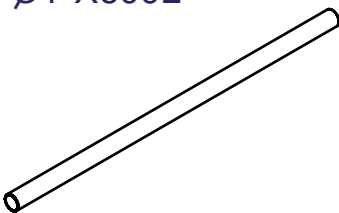

K[1PCS]

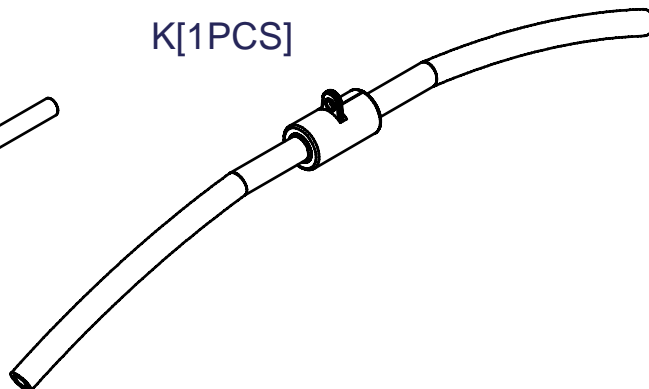

L[1PCS]  
8313-130

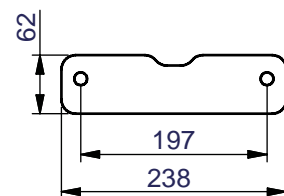

# DLAT ASSEMBLY INSTRUCTIONS

## PARTS ILLUSTRATION SHEET

M[1PCS]  
8343-146

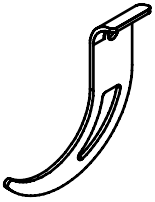

N[1PCS]  
8343-147



O[2PCS]  
8343-140

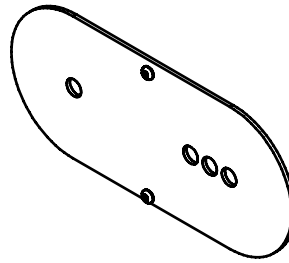

P[1PCS]  
8290-001

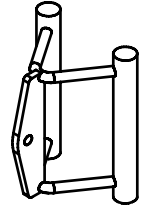

Q[1PCS]  
9121-054

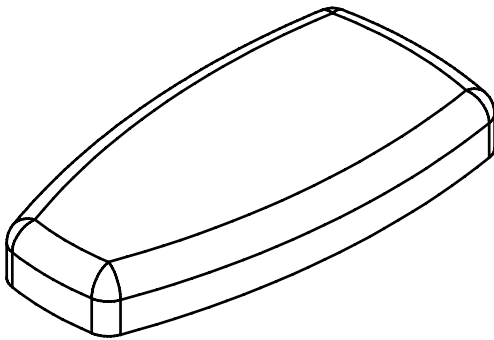

R[2PCS]  
9161-021B  
Ø150X250L

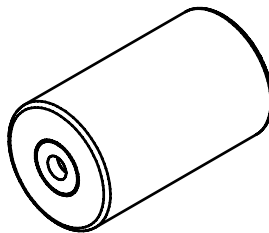

# DLAT ASSEMBLY INSTRUCTIONS

## FRAME PARTS ILLUSTRATION SHEET

S[1PCS]  
6610-001

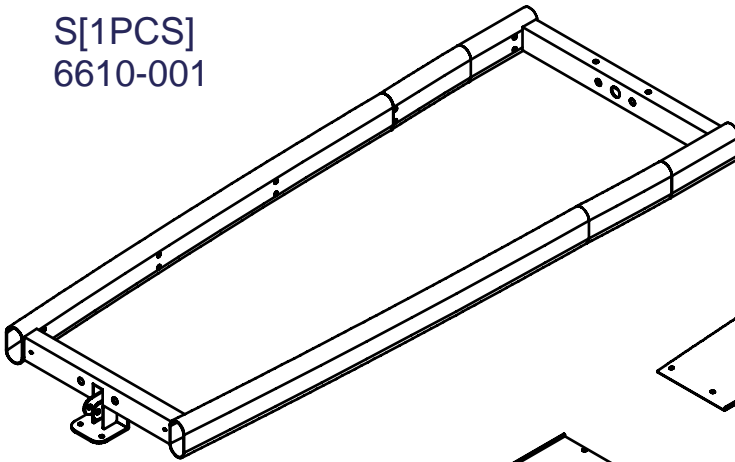

T[1PCS]  
8380-044

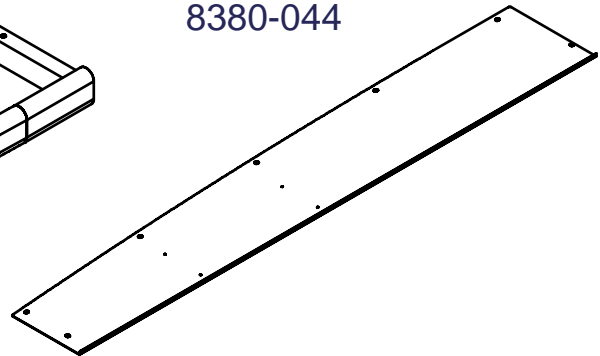

U[1PCS]  
8380-052

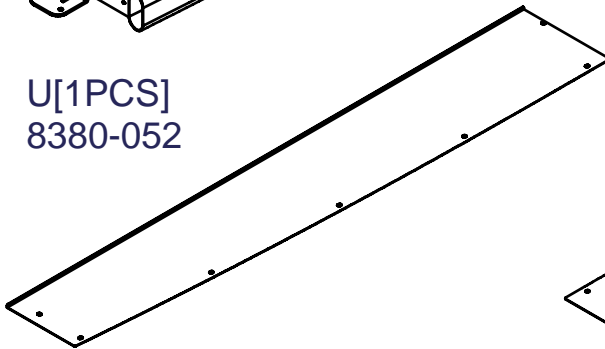

V[1PCS]  
8380-045

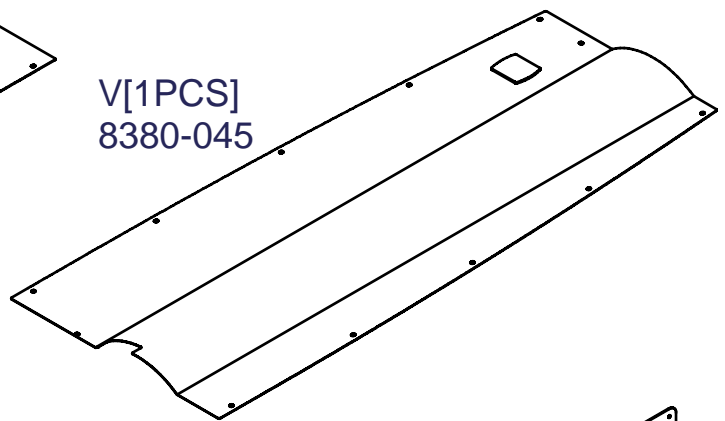

W[2PCS]  
Ø3/4"X1932L

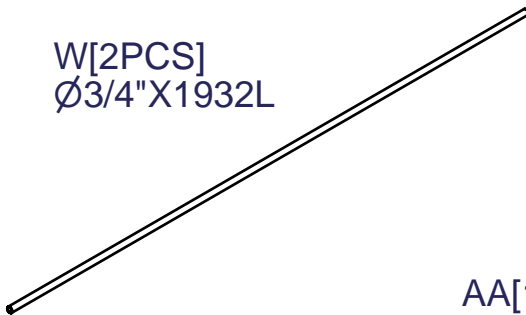

Z[1PCS]  
9440-165

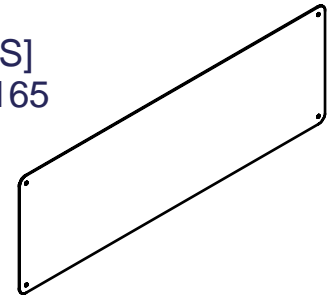

X[1PCS]  
9211-111

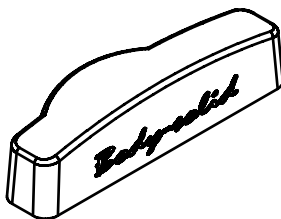

AA[12PCS]  
8321-040  
both side

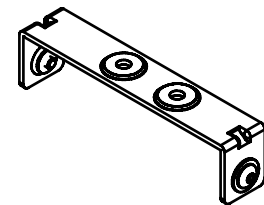
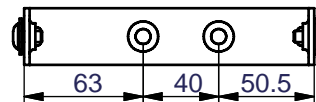

AB[2PCS]  
8321-040  
one side

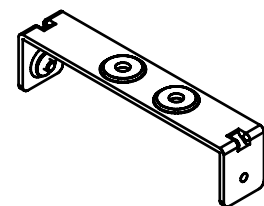
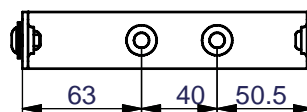

Y[2PCS]  
8313-144

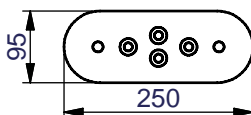

# DLAT ASSEMBLY INSTRUCTIONS

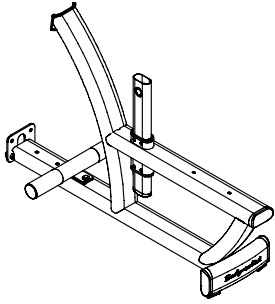

Above shows STEP 1  
assembled and completed

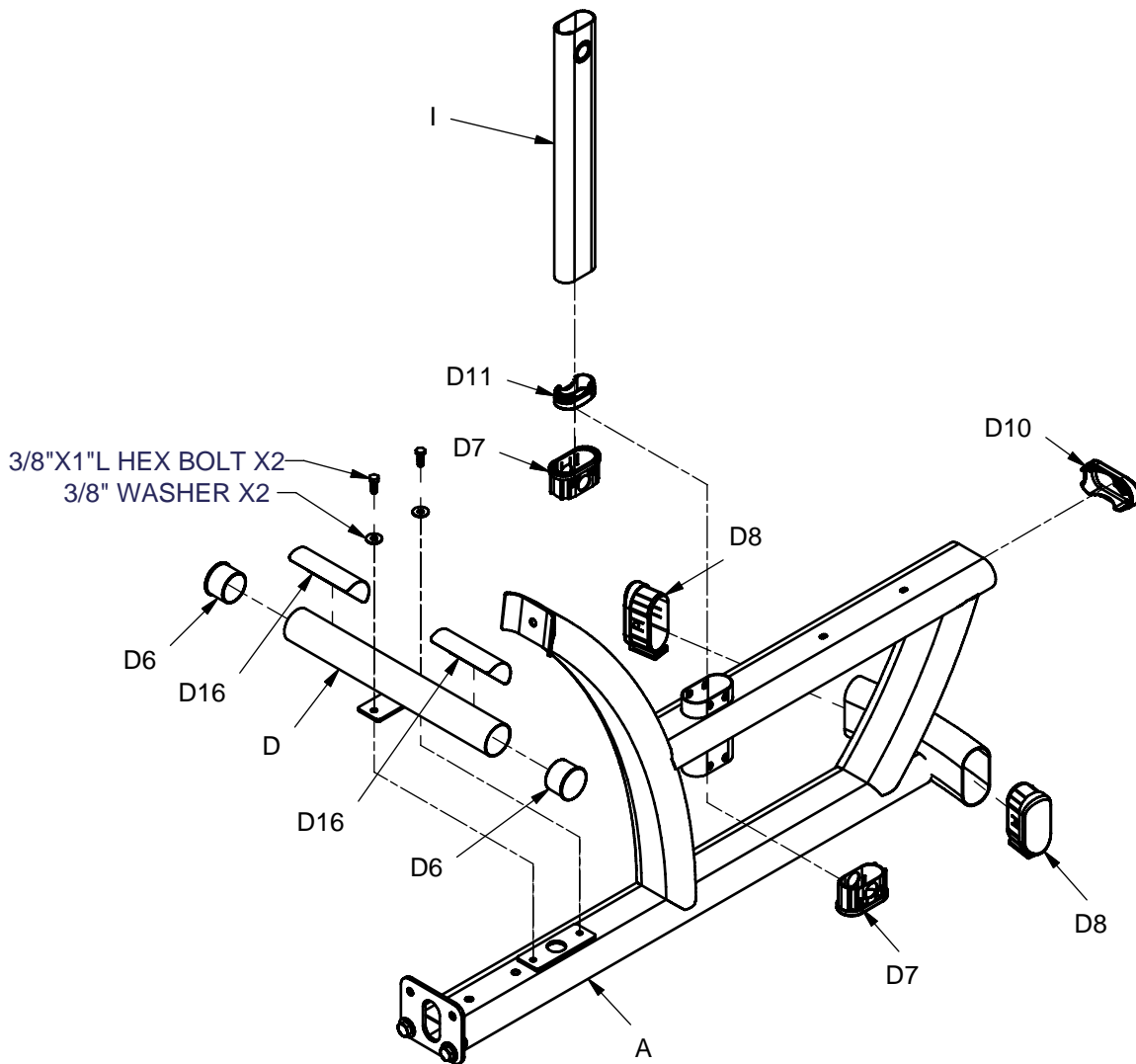

# DLAT ASSEMBLY INSTRUCTIONS

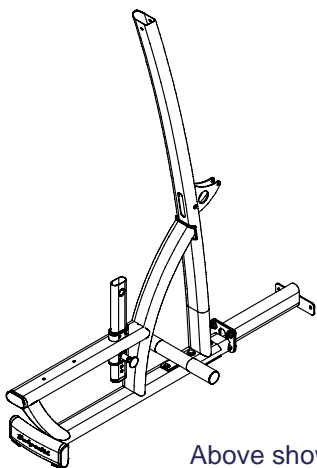

Above shows STEP 2  
assembled and completed

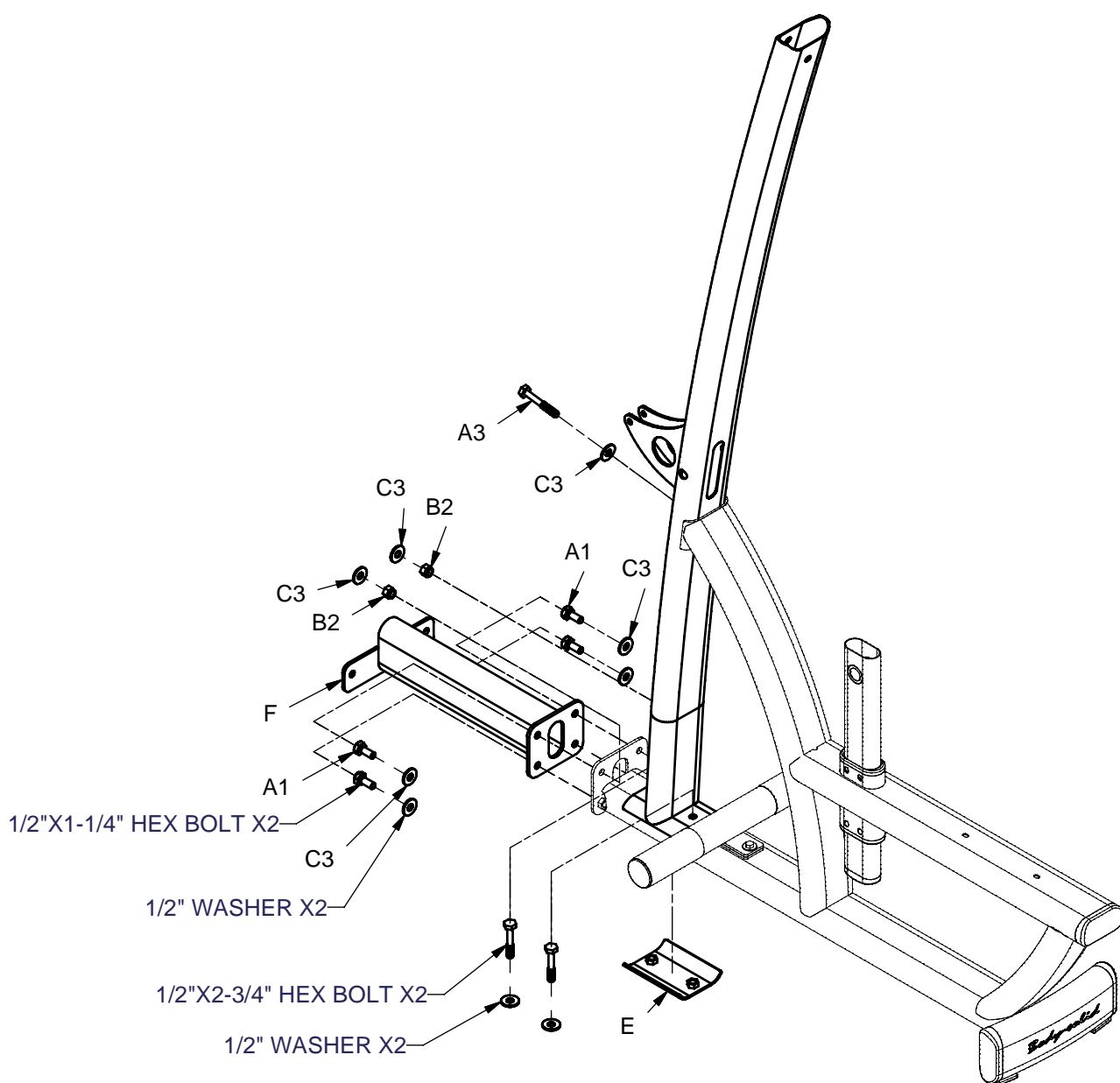

# DLAT ASSEMBLY INSTRUCTIONS

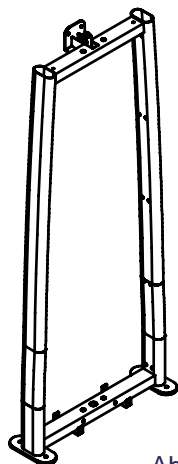

Above shows STEP 3  
assembled and completed

## DLAT single weight stack assembly instructions

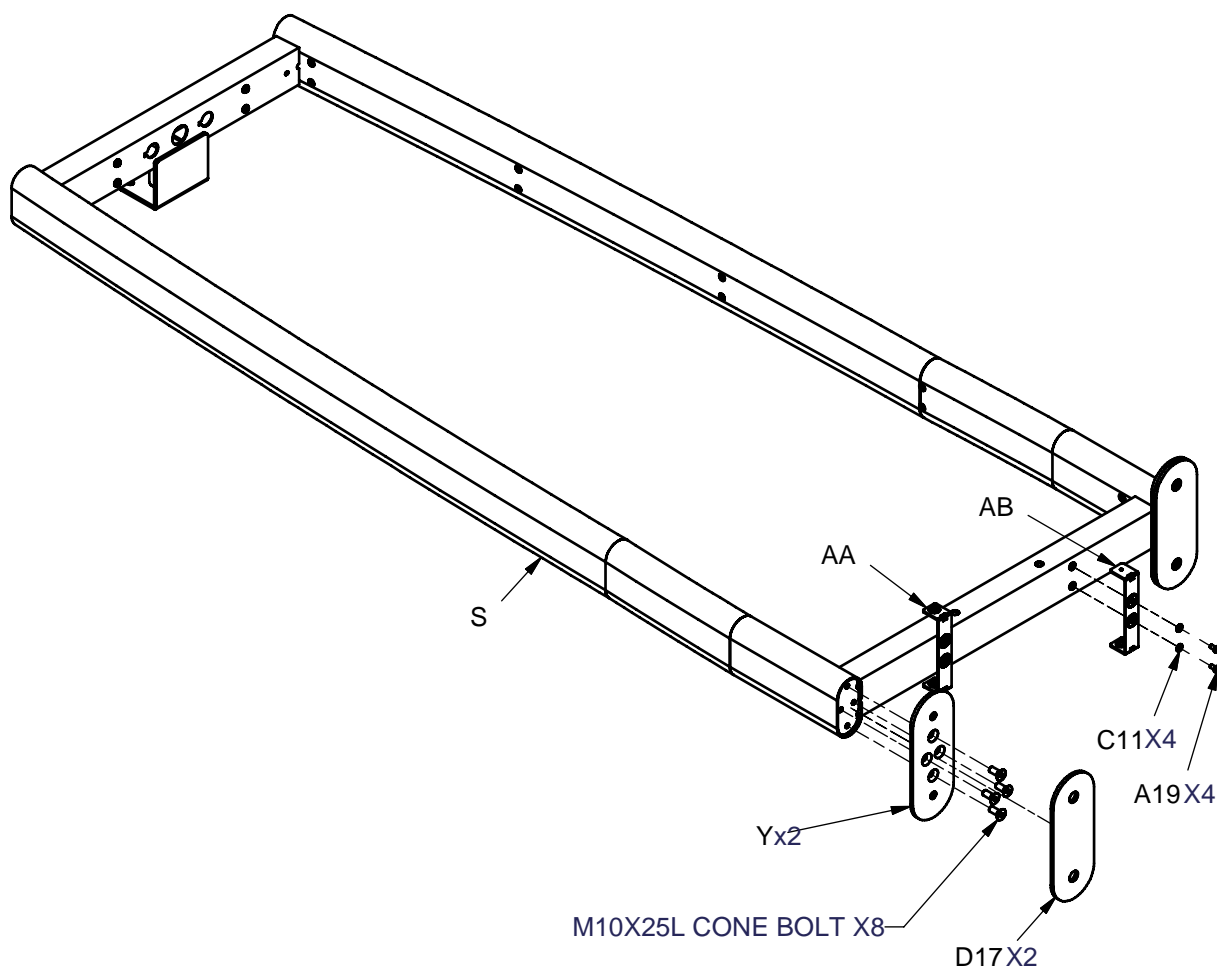



# DLAT ASSEMBLY INSTRUCTIONS

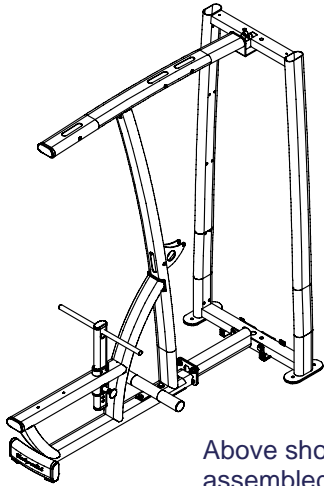

Above shows STEP 4 assembled and completed

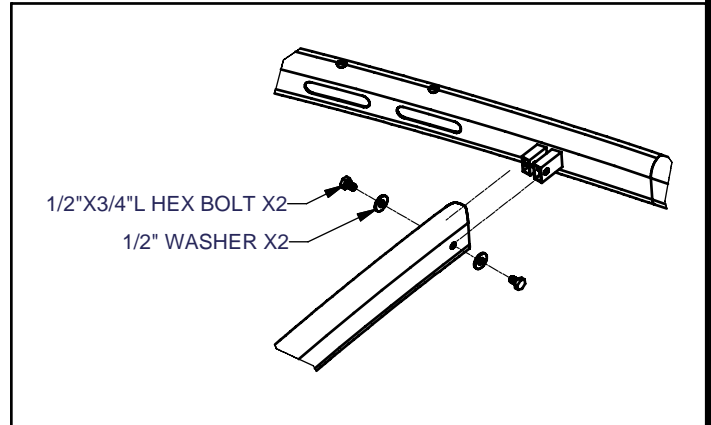

1/2"X3/4"L HEX BOLT X2

1/2" WASHER X2

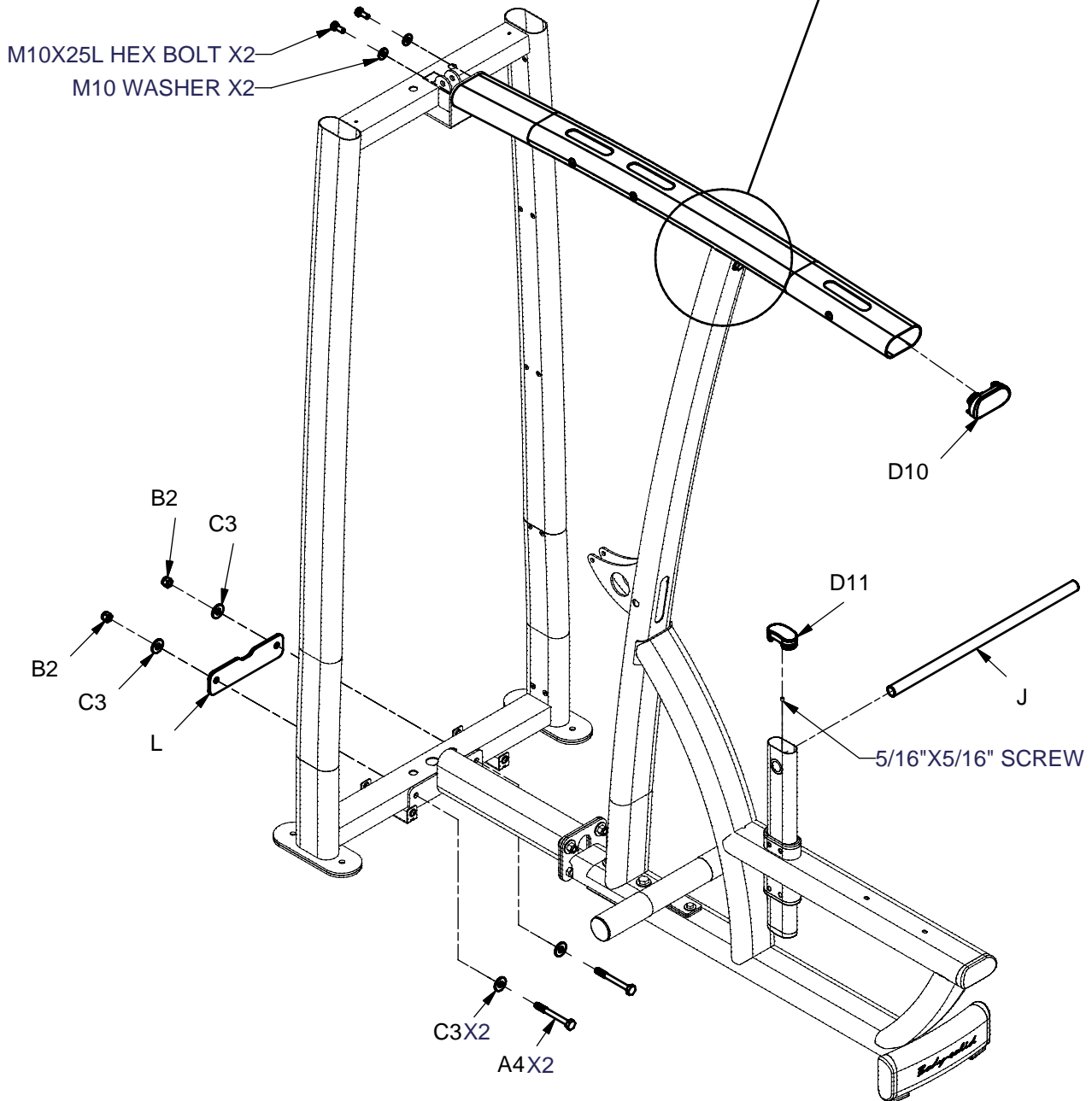

M10X25L HEX BOLT X2

M10 WASHER X2

B2

C3

B2

C3

L

D10

D11

J

5/16"X5/16" SCREW

C3X2

A4X2

# DLAT ASSEMBLY INSTRUCTIONS

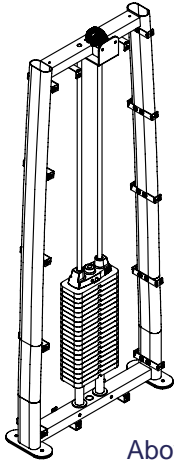

Above shows STEP 5 assembled and completed

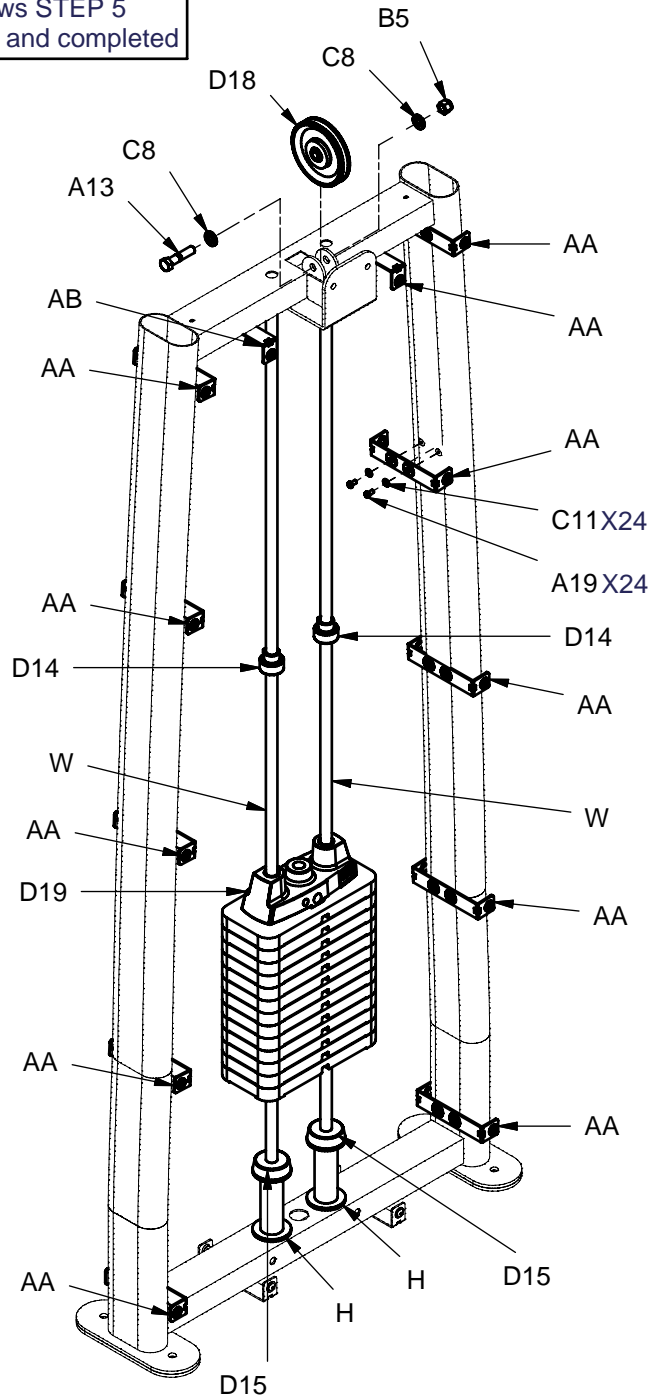

# DLAT ASSEMBLY INSTRUCTIONS

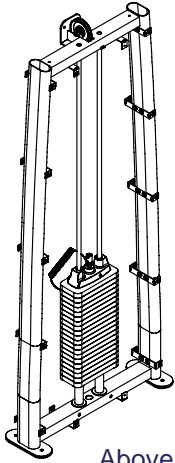

Above shows STEP 6  
assembled and completed

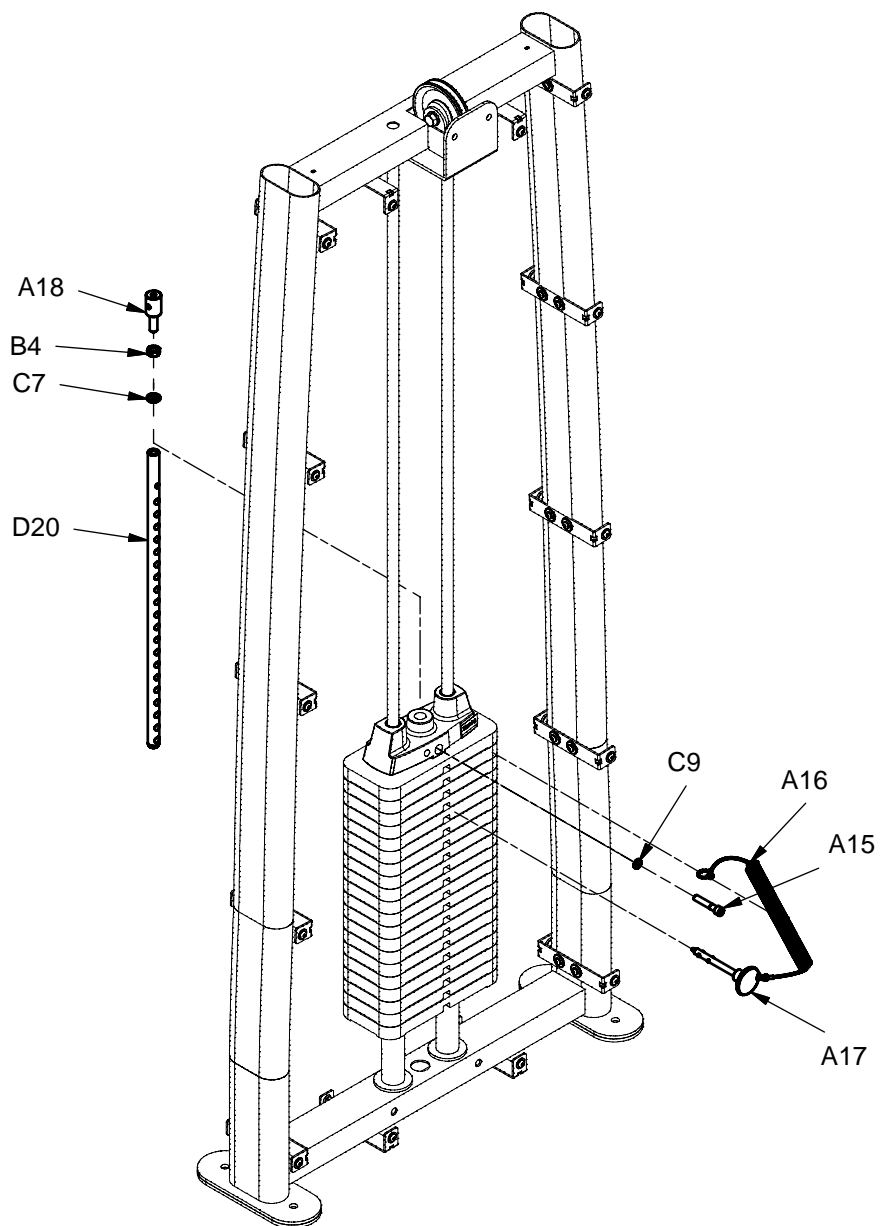

# DLAT ASSEMBLY INSTRUCTIONS

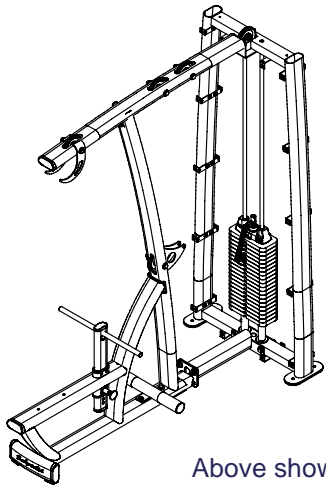

Above shows STEP 7 assembled and completed

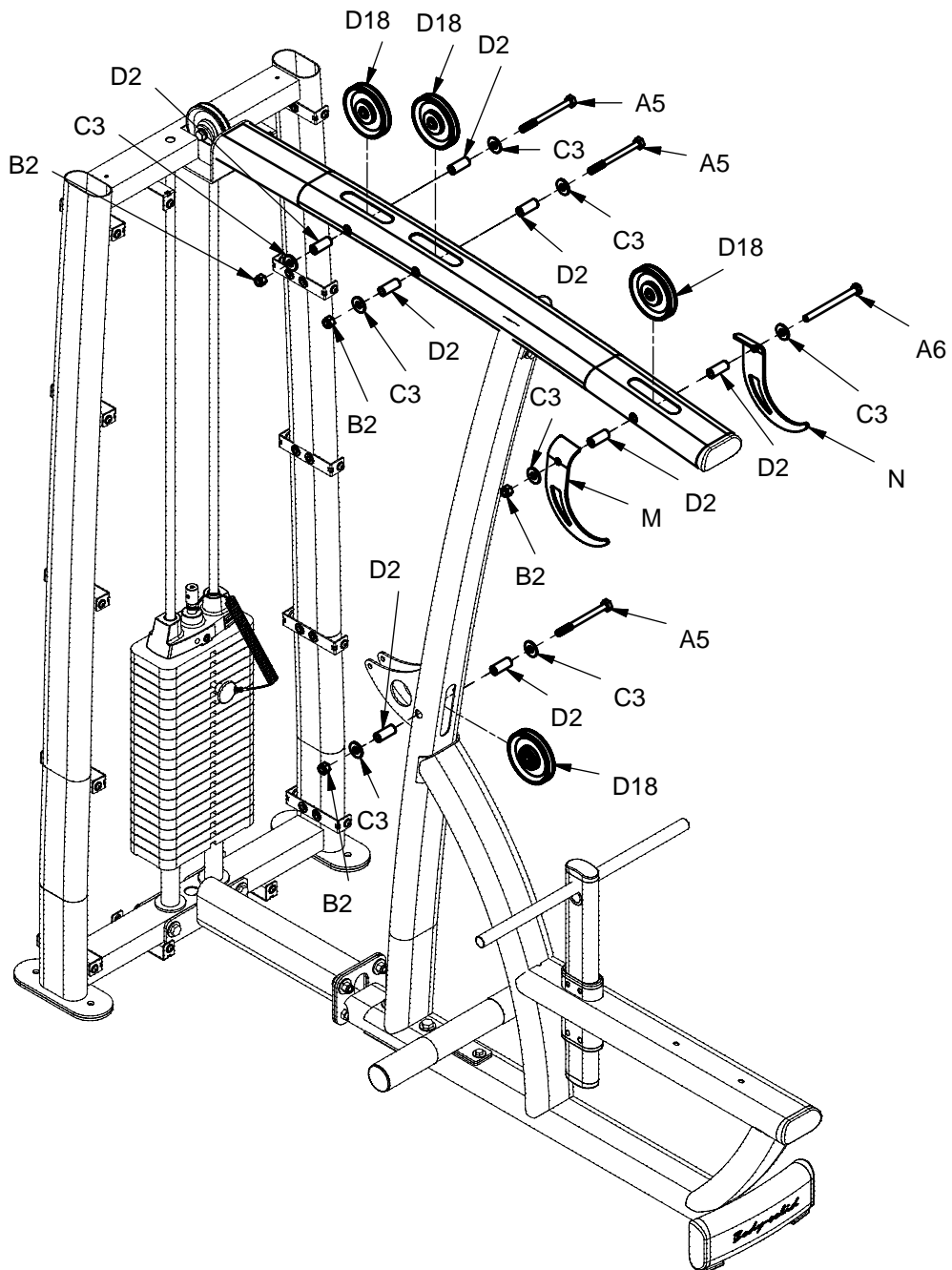

# DLAT ASSEMBLY INSTRUCTIONS

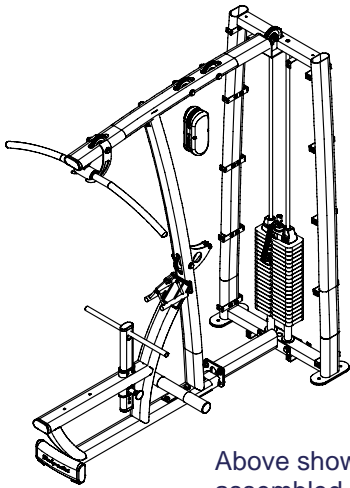

Above shows STEP 8 assembled and completed

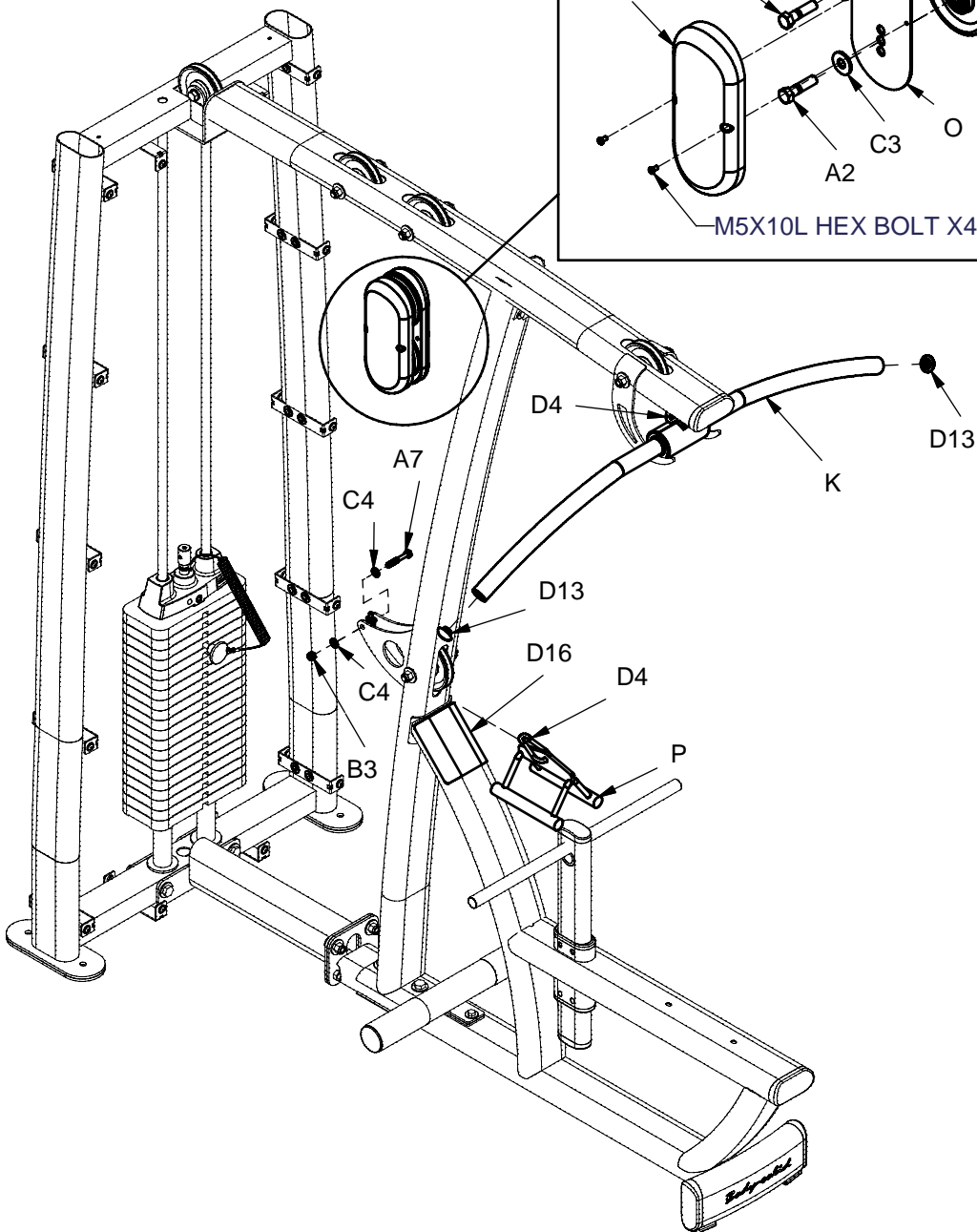
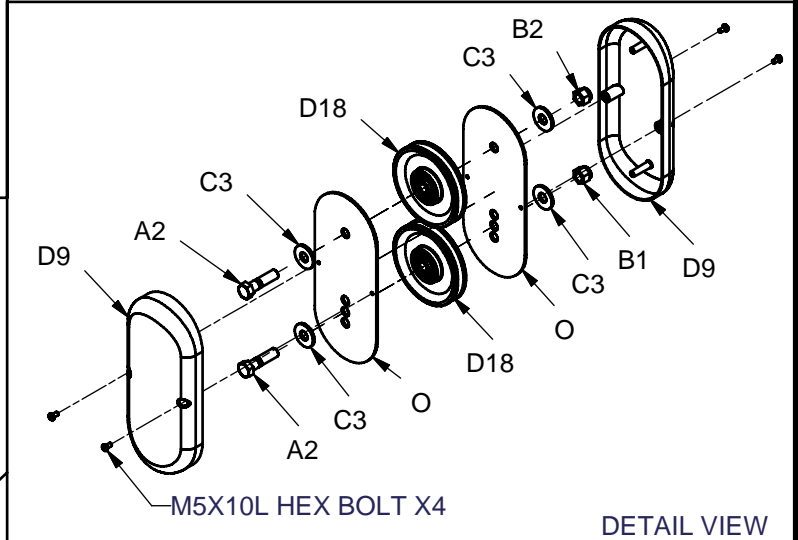

# DLAT ASSEMBLY INSTRUCTIONS

Cable to match illustration

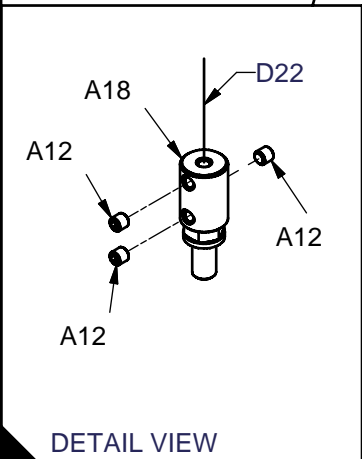
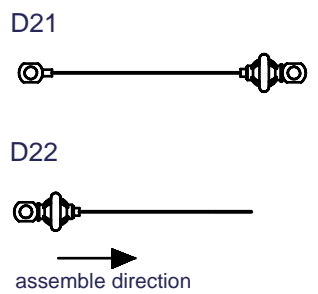
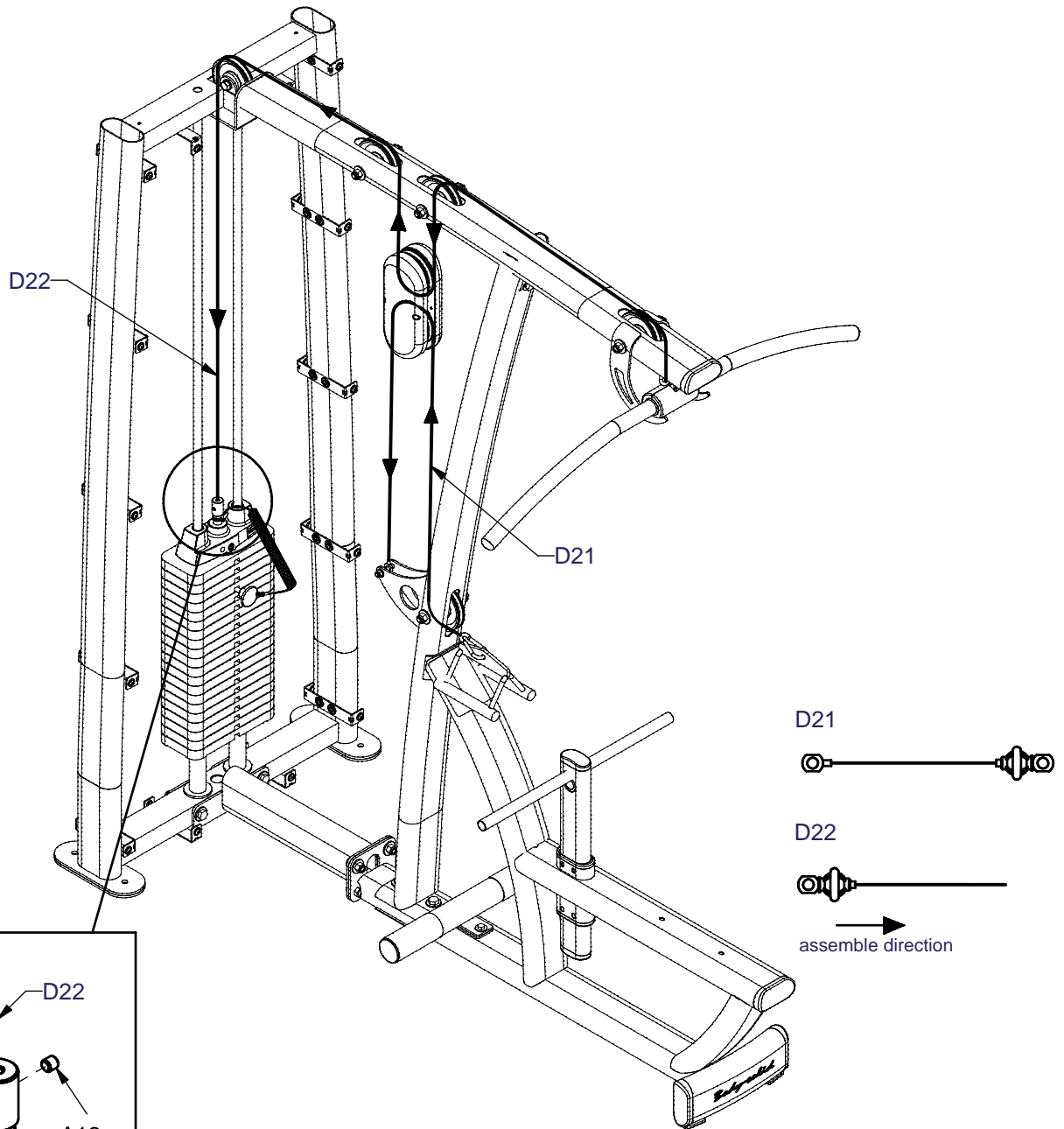

DETAIL VIEW

DLAT-102006



# DLAT ASSEMBLY INSTRUCTIONS

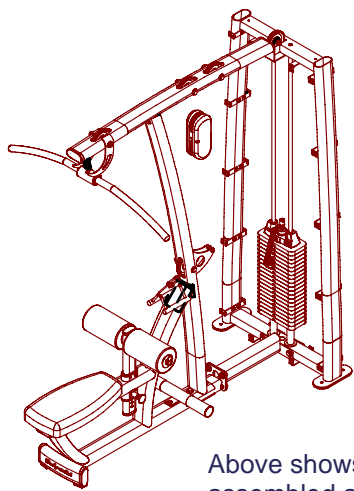

Above shows STEP 9  
assembled and completed

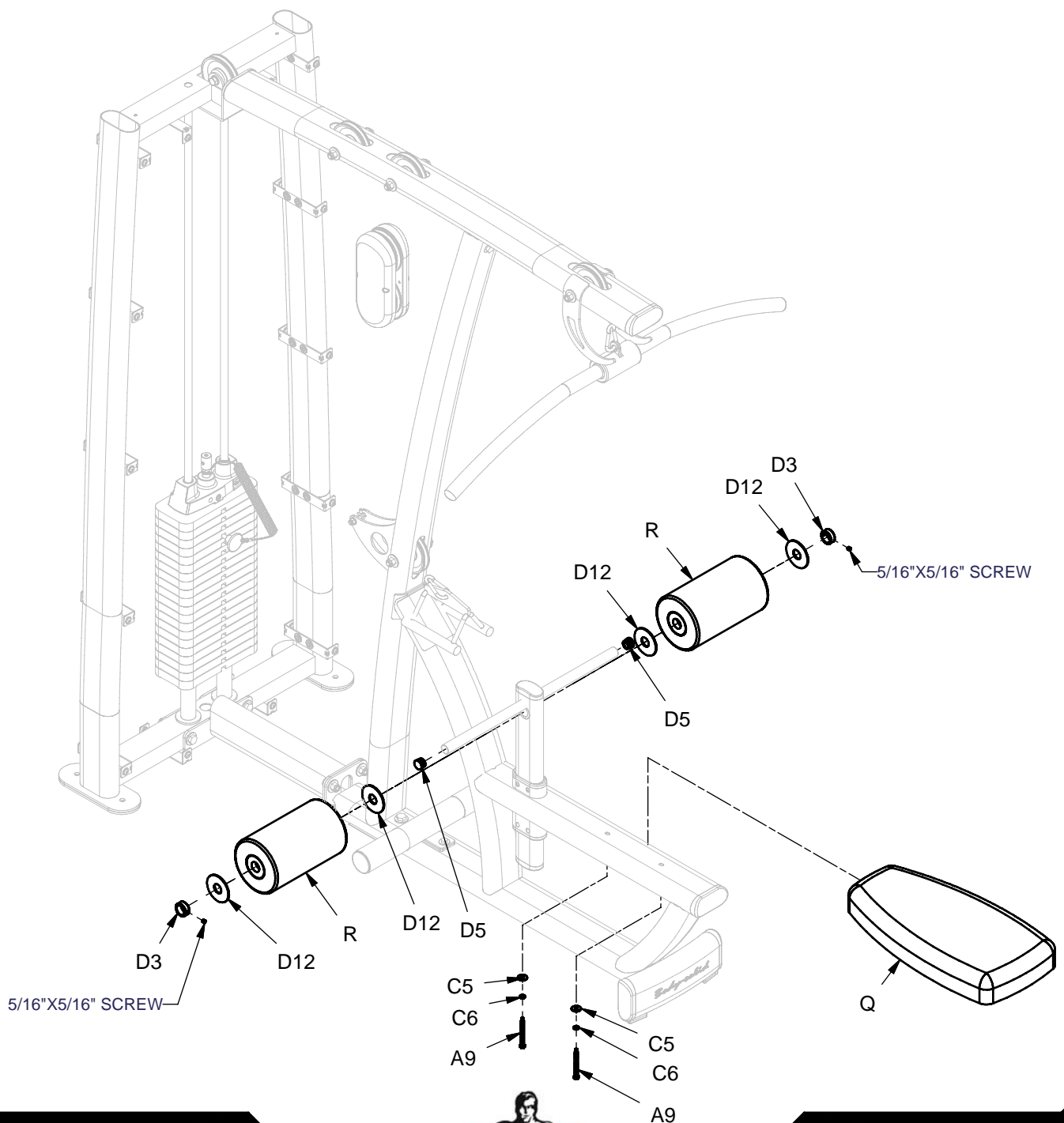

# DLAT ASSEMBLY INSTRUCTIONS

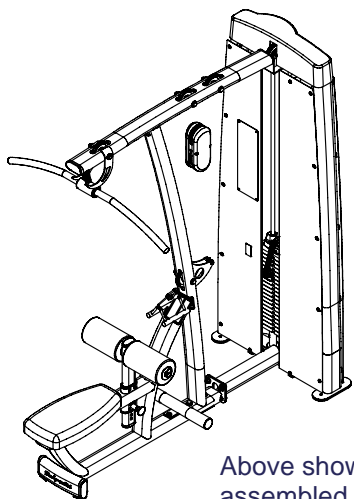

Above shows STEP 10  
assembled and completed

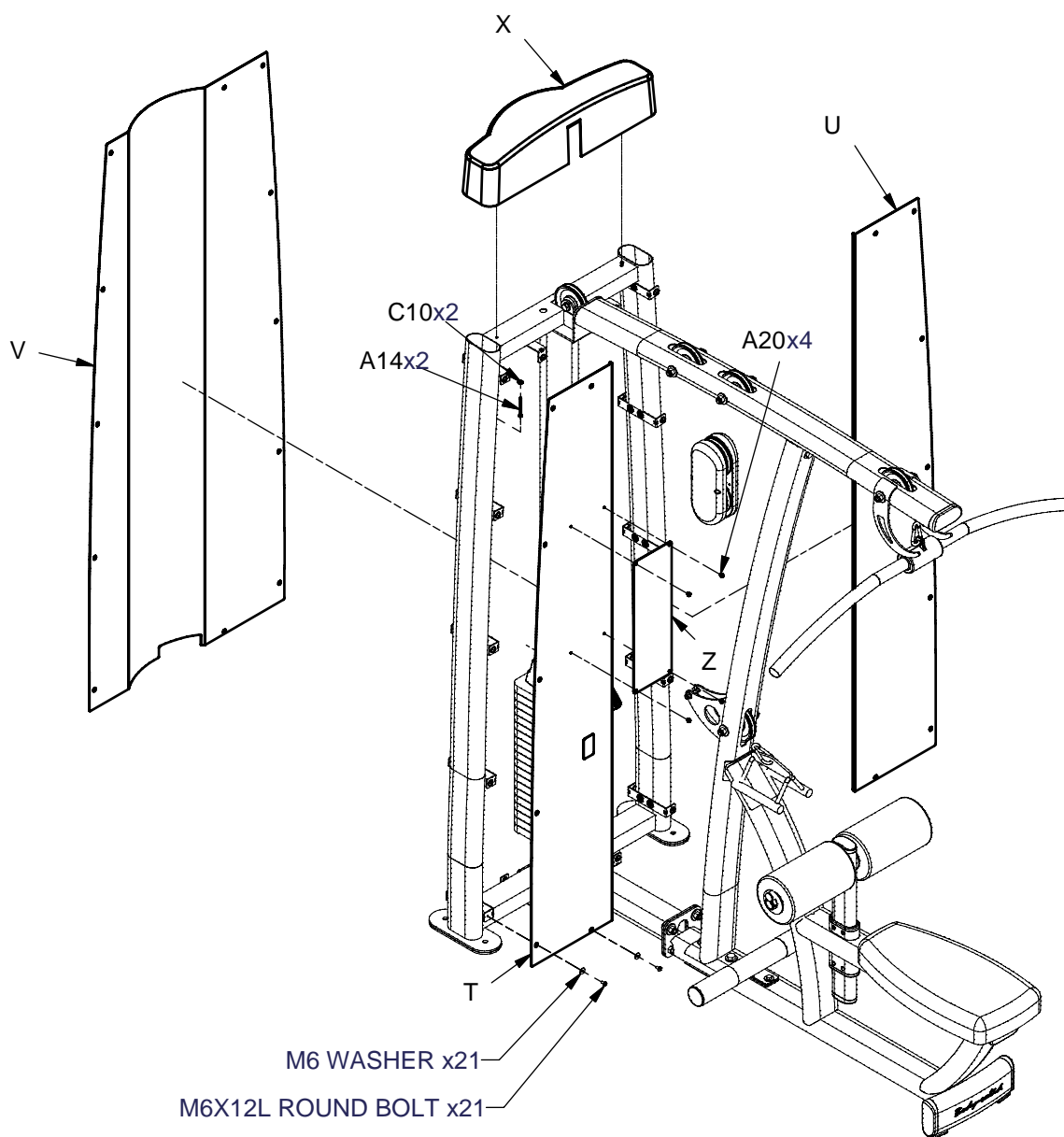



# DLAT ASSEMBLY INSTRUCTIONS

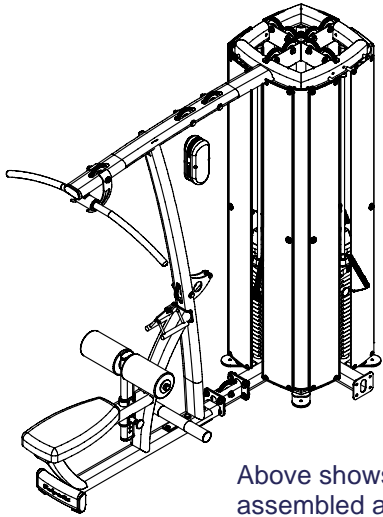

Above shows STEP 11 assembled and completed

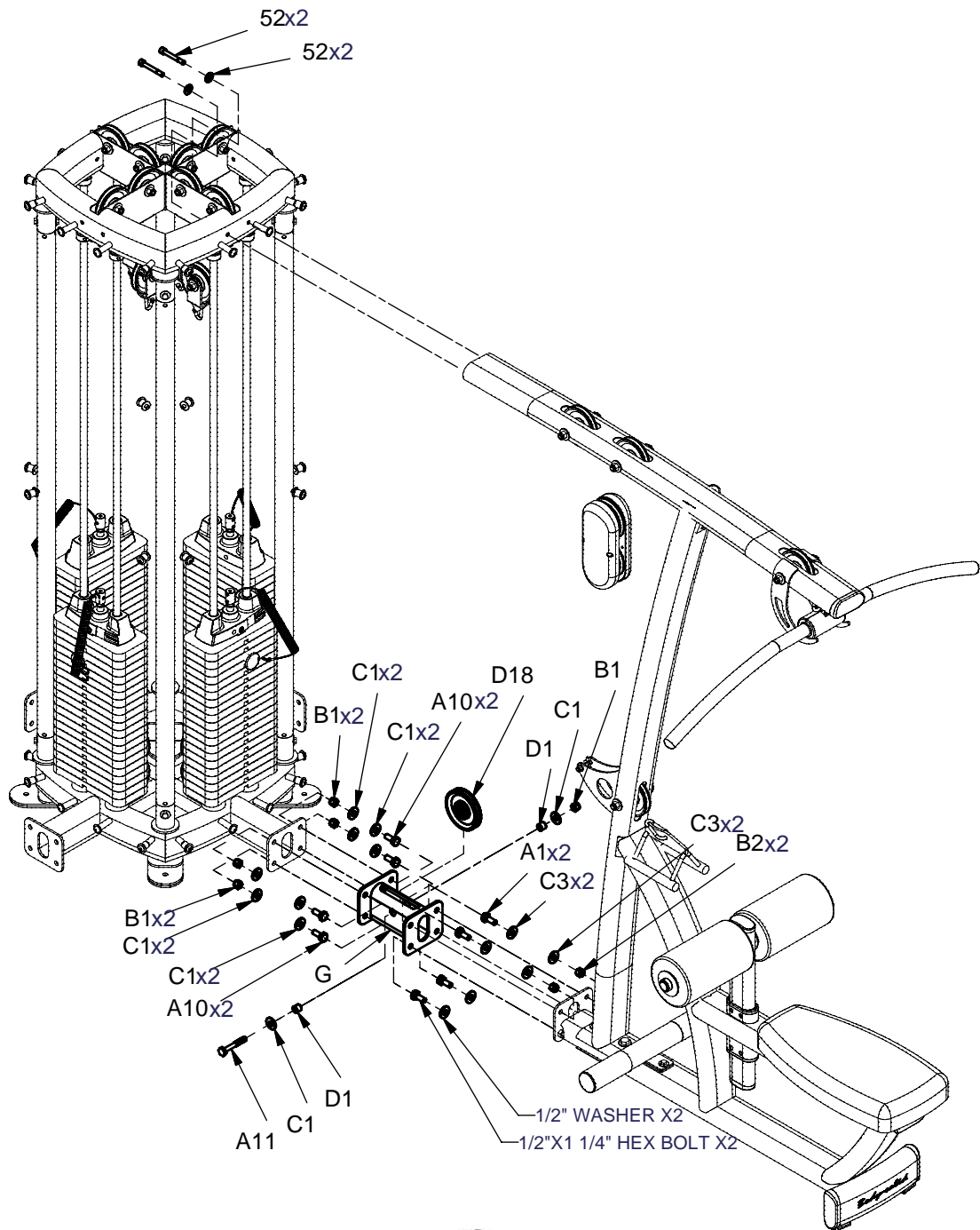

# DLAT ASSEMBLY INSTRUCTIONS

Cable to match illustration

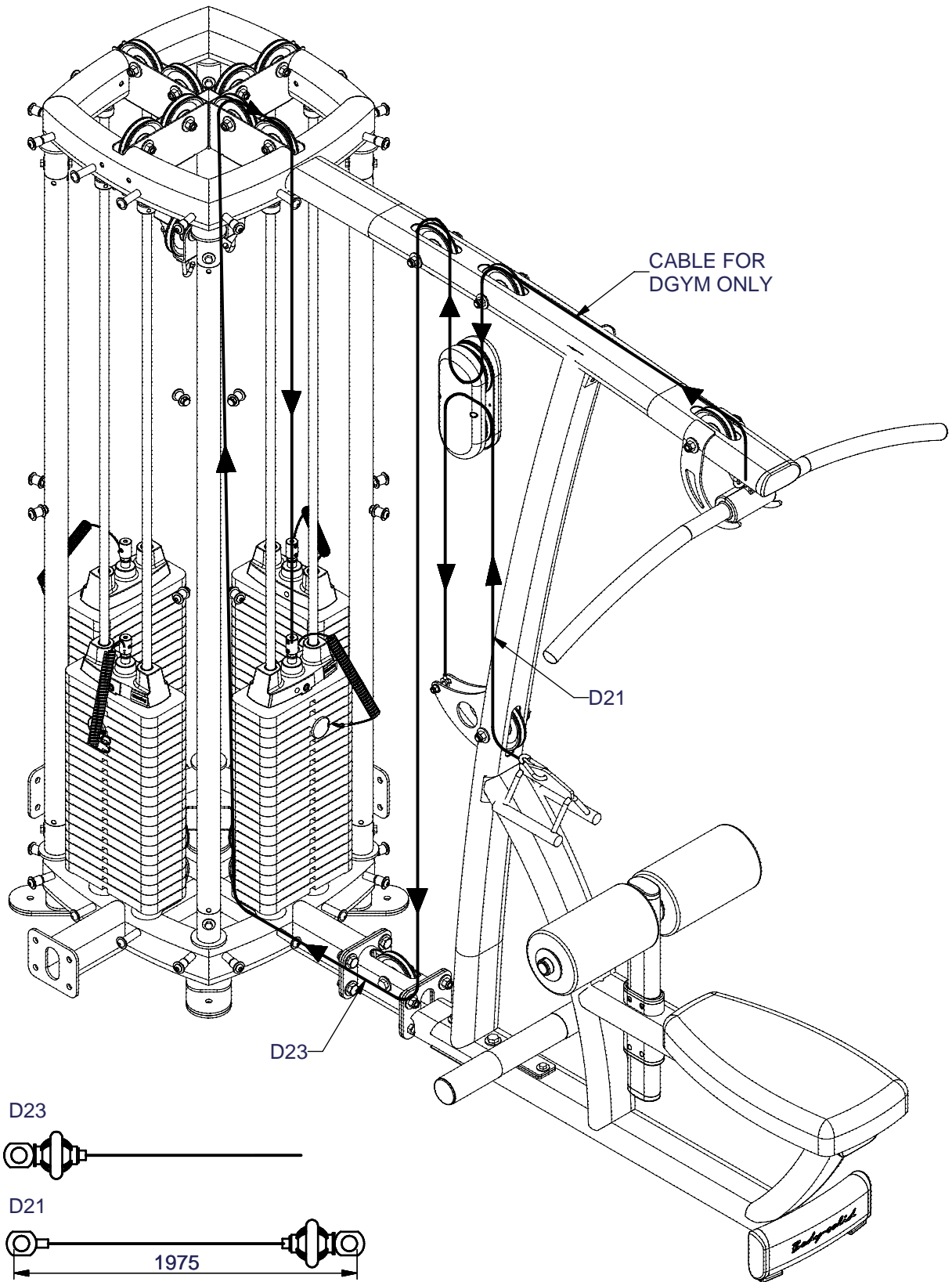

# DLAT ASSEMBLY INSTRUCTIONS

